

Tyler Henretty, Kim Finch, & Justin Morris

Project 2: **AKRON DECO**

Advanced Graphic Design Spring 2024

**Research**

Research | Building Decision

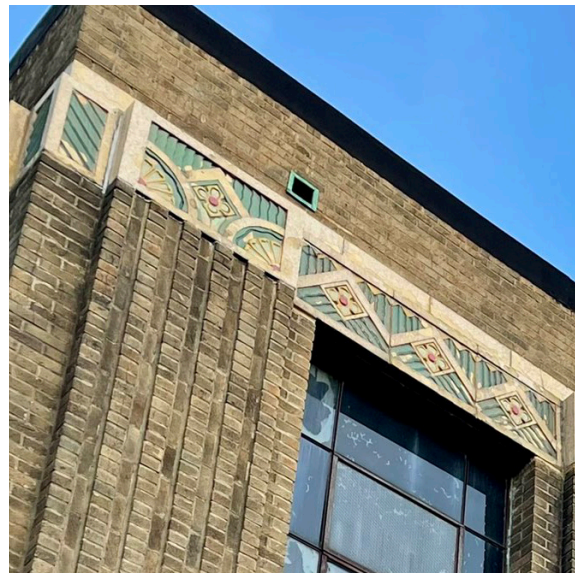

Research | Building Decision



Research | Building Decision

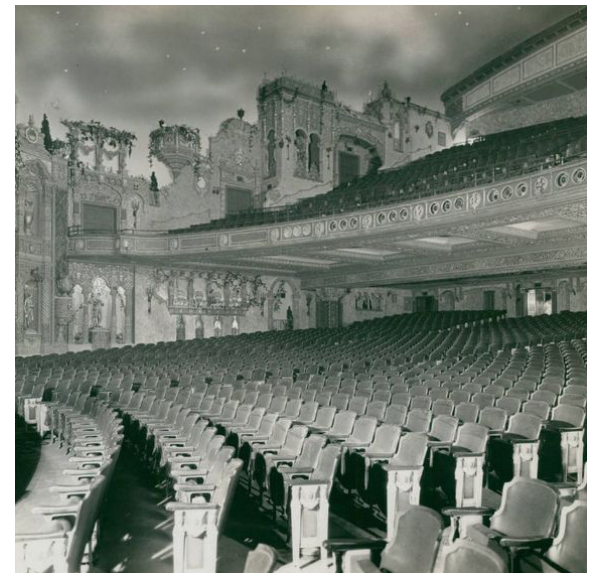

Research | Building Decision



Research | Building Decision | Chosen



Research | Building Decision | Chosen

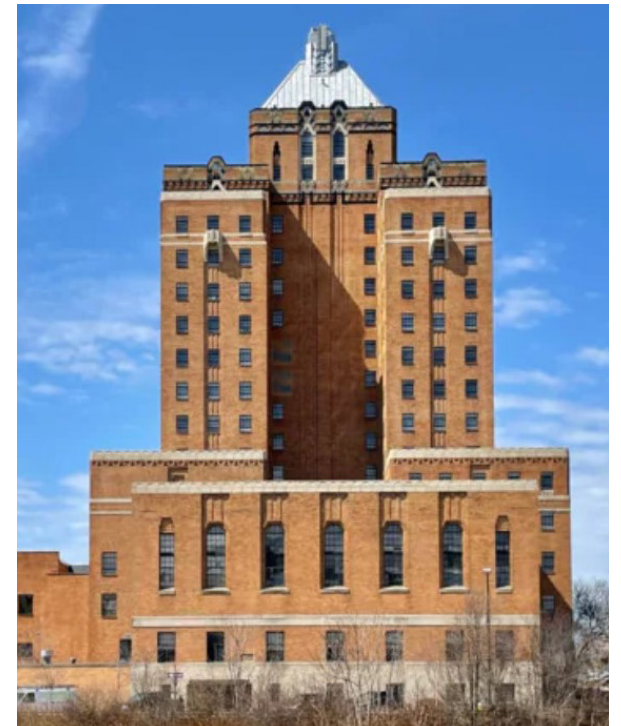



Research | Building Decision | Chosen

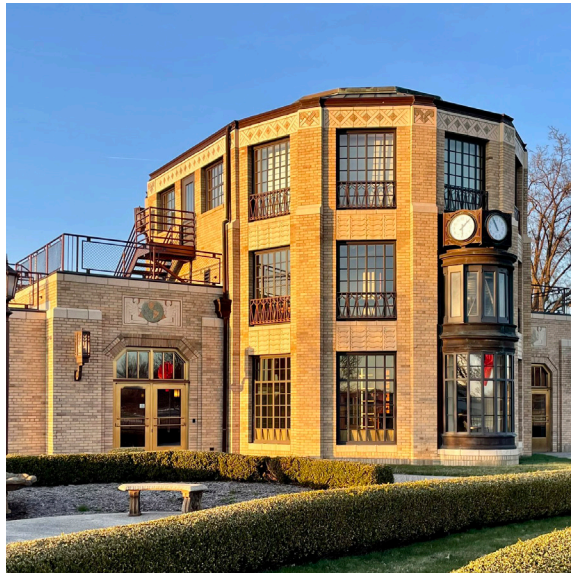

Research | Inspiration



Research | Inspiration

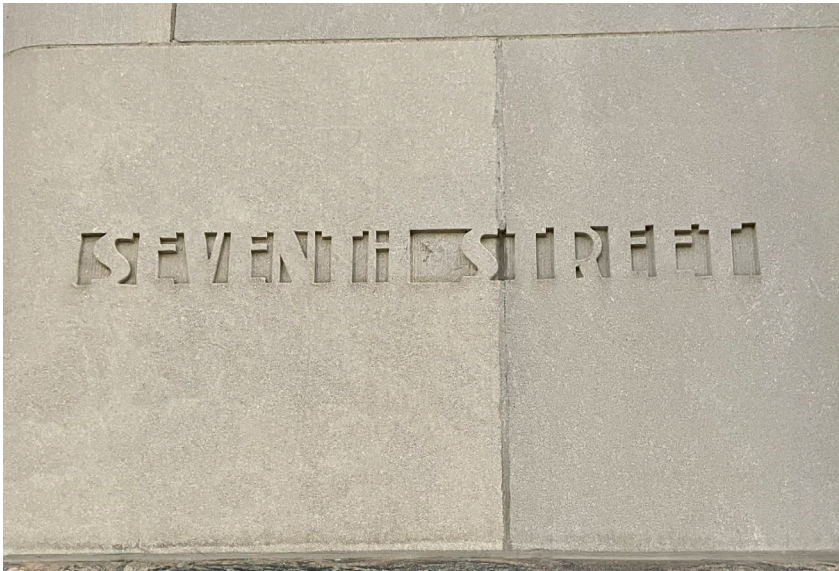

Research | Inspiration



Research | Inspiration



# Research | Inspiration



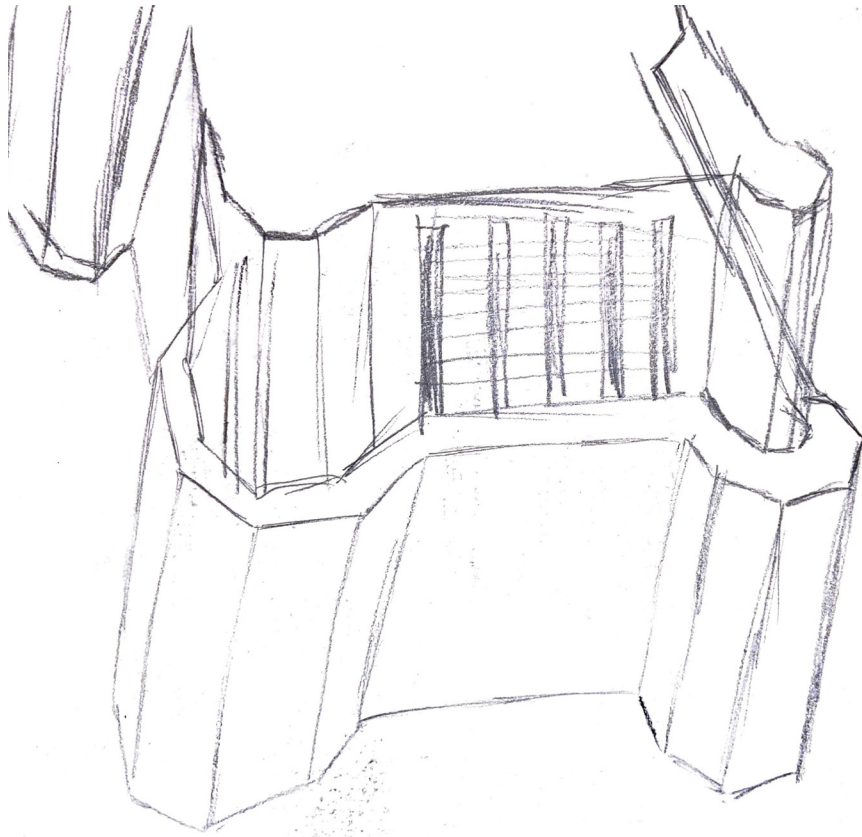

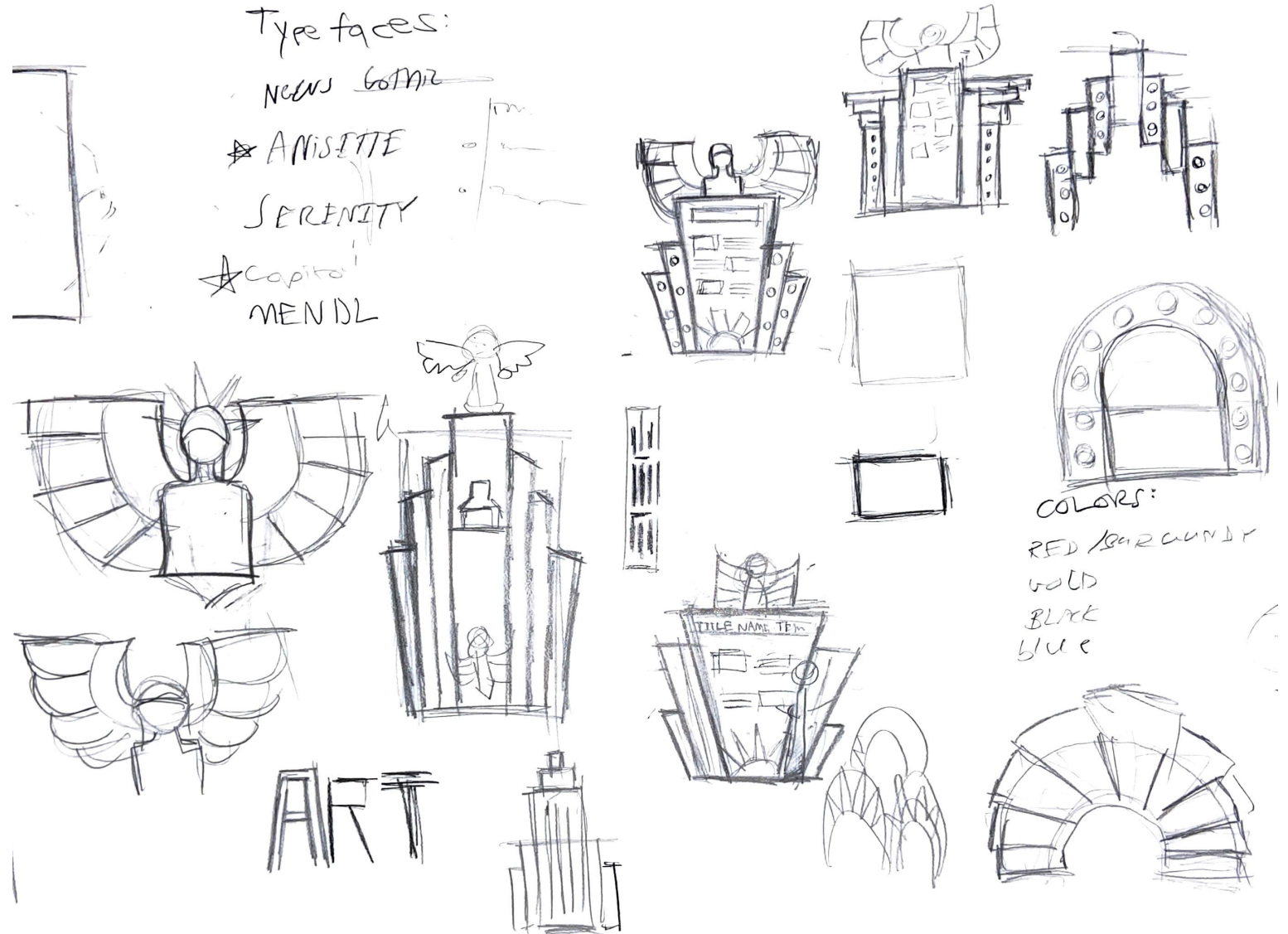



Research | Sketches

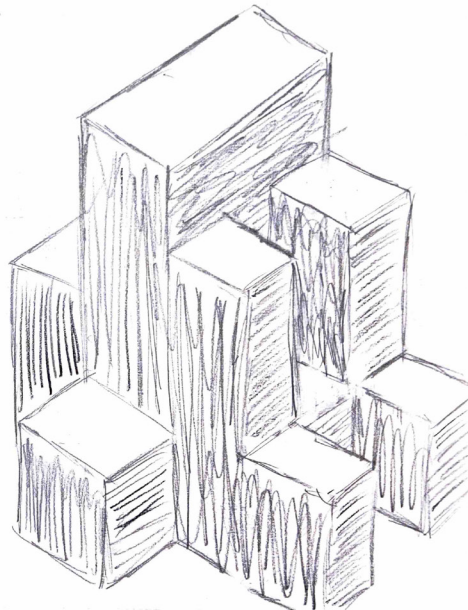
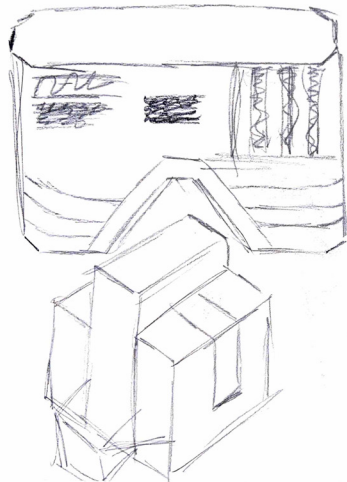
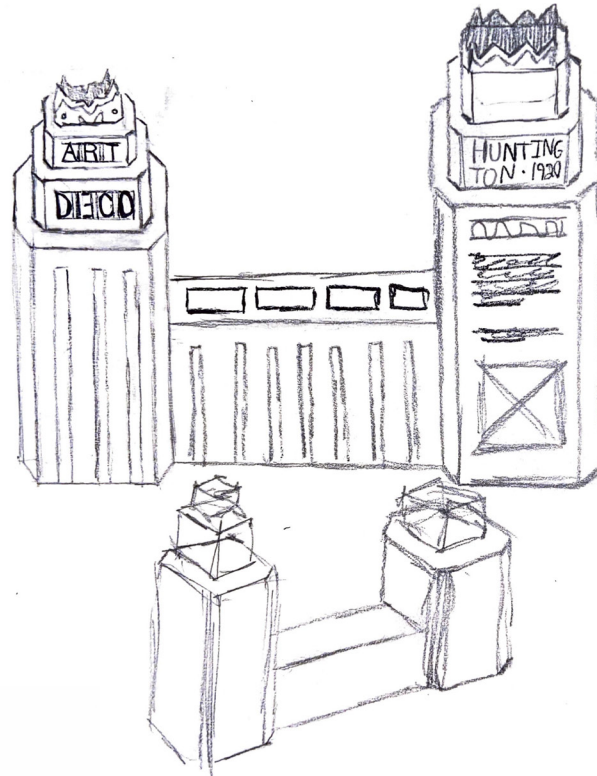
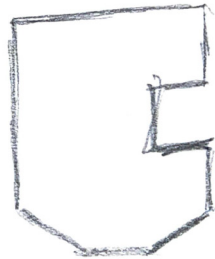
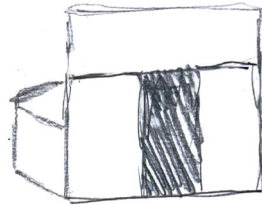
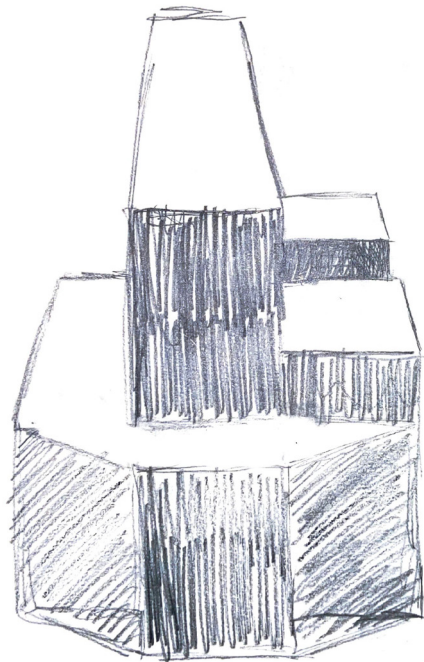

## Research | Huntington Tower



Constructed in 1926, the Huntington Building in Akron, Ohio, is a stunning example of Art Deco architecture, reflecting the design sensibilities of the early 20th century. Designed by the architectural firm of Graham, Anderson, Probst & White, the building stands as a testament to the opulence and modernity of the era.

Art Deco, characterized by its geometric shapes, sleek lines, and lavish ornamentation, is evident throughout the Huntington Building's design. The facade features intricate carvings, stylized motifs, and decorative elements, all meticulously crafted to create a sense of elegance and sophistication.

One of the most striking features of the Huntington Building is its soaring height and distinctive setbacks, which were common elements in Art Deco skyscraper design. These setbacks not only served practical purposes, allowing for increased natural light and ventilation, but also contributed to the building's iconic silhouette.

The lobby of the Huntington Building is equally impressive, with its marble floors, ornate moldings, and elaborate metalwork. The grandeur of the space is accentuated by its soaring ceilings and Art Deco light fixtures, creating an atmosphere of luxury and glamour.

Originally built as the headquarters for the First Central Trust Company, the Huntington Building played a significant role in Akron's banking and financial sector during the early 20th century. Its prime location in downtown Akron further solidified its status as a symbol of prosperity and progress.

Over the years, the Huntington Building has undergone various renovations and updates to maintain its historic charm while adapting to modern needs. Today, it continues to serve as a hub for business and commerce, housing offices, retail establishments, and other commercial ventures.

## Research | Akron YMCA Building



Constructed in 1905, the Akron YMCA Building was designed by architect Charles Sumner Schneider, a prominent figure in the city's architectural landscape. Its construction was a response to the burgeoning need for a central hub for community activities and social services in Akron.

At the turn of the 20th century, Akron was experiencing rapid industrialization, fueled by the burgeoning rubber industry. With an influx of workers and families settling in the city, there arose a demand for spaces that fostered physical, mental, and social well-being.

The Akron YMCA Building served as a beacon of hope and support for the community, particularly during times of hardship. During World War I, it provided essential services to soldiers and their families, offering recreational activities, educational programs, and support networks. Similarly, during the Great Depression, it became a refuge for the unemployed, offering job training programs, meals, and temporary shelter.

The Akron YMCA Building was envisioned as more than just a recreational facility; it was a place where individuals could engage in physical fitness activities, educational programs, and social gatherings. Its architectural design mirrored the prevailing Beaux-Arts style, characterized by grandiosity and classical elements.

The building boasted a stately facade adorned with ornate detailing, including Ionic columns, decorative moldings, and a grand entrance. Today, the building stands as a testament to the enduring legacy of community service and civic engagement.

While its architectural splendor may have faded over time, its significance as a symbol of unity and resilience remains undiminished. As Akron continues to forge ahead into the 21st century, the Akron YMCA Building serves as a reminder of the importance of nurturing the well-being of individuals and communities alike.

## Research | Akron-Fulton Intl Airport



The Akron Fulton Airport was dedicated in 1929 and has a long and storied history. Bain “Shorty” Fulton founded the airport, a pilot in World War II. In 1924, “Shorty” Fulton purchased a farm on Massillon Road in Akron. This land was less than three miles from his place of employment, Goodyear Tire and Rubber.

His plan was to teach people to fly, offer airplane rides and fly at county fairs. At this time the United States Post Office took over the airmail service from the Army Air Service. The United States Post Office awarded the City of Akron the regional airmail center franchise in 1925. In 1928 the navy signed a contract with Goodyear to build two Zeppelin airships.

Goodyear Aerospace built the Corsair at its factory by the Akron Fulton Airport. During the height of production. With its aggressive shape and ferocious speed, the Corsair was a vital component to Allied air superiority in the South Seas. The Akron-Fulton Administration building sits just north of the Goodyear Airdock, where the first lighter-than-air ships were produced. It also stands as one of the few Goodyear Blimp hangars to exist.

The building serves a significant contribution to the development of early commercial aviation in Akron. Both its Art Deco architecture and interior are representations of the development of airports during the first major expansion of air travel in the 1920s and 1930s. In 1985, the Akron Fulton International Airport was recognized as the 3rd National Landmark of Soaring by the National Soaring Museum.

Home to the original Goodyear Airdock where the first lighter than airships were built, the airport also is home to the All American Soap Box Derby, and is within five miles of the world renown Firestone Country Club and within four miles of the City of Akron’s central business district.















Research | YMCA Building

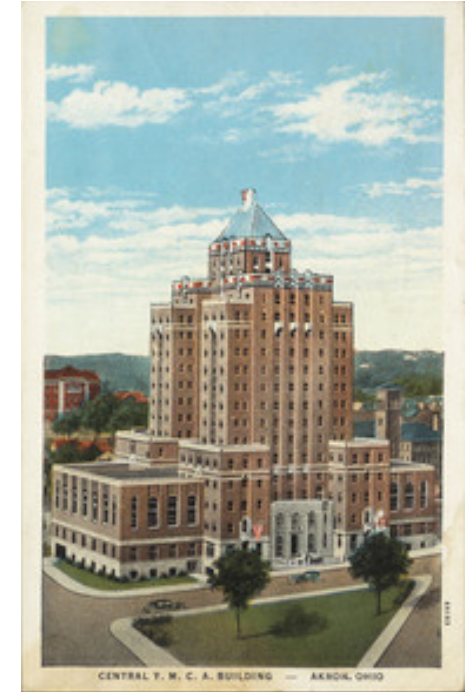
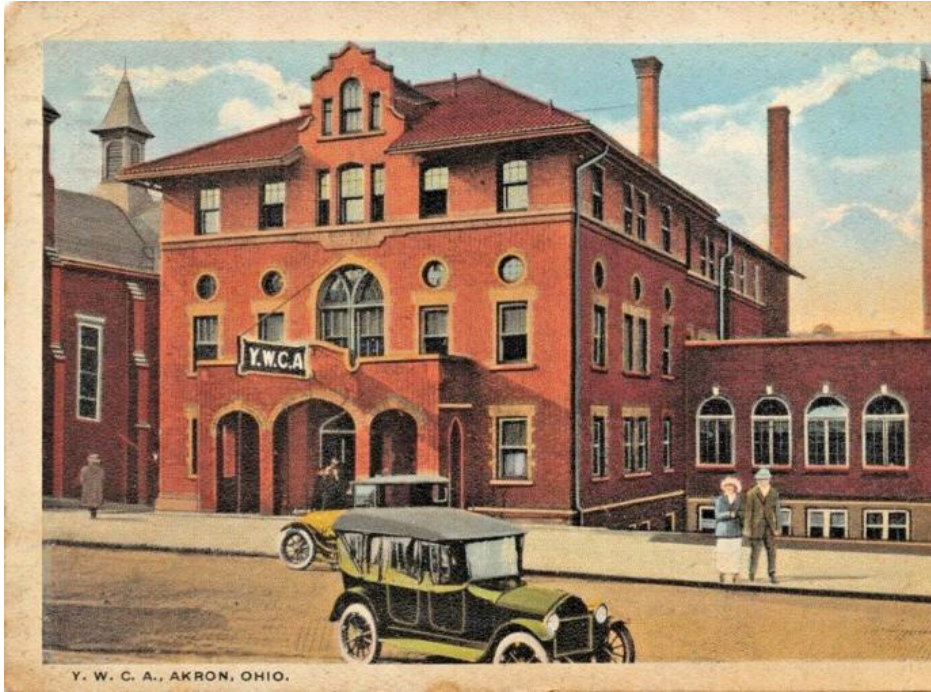

Research | Huntington Tower

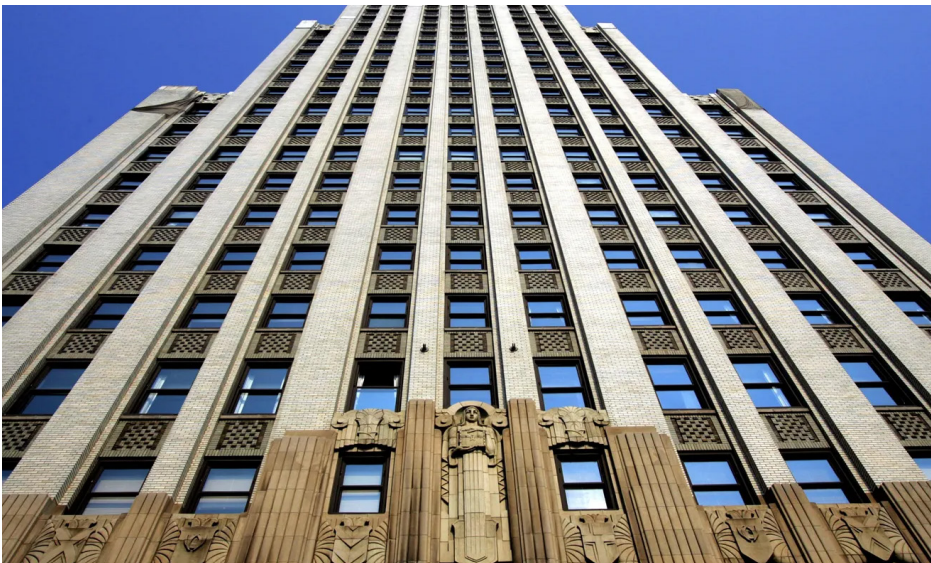

# Research | Akron-Fulton Intl Airport

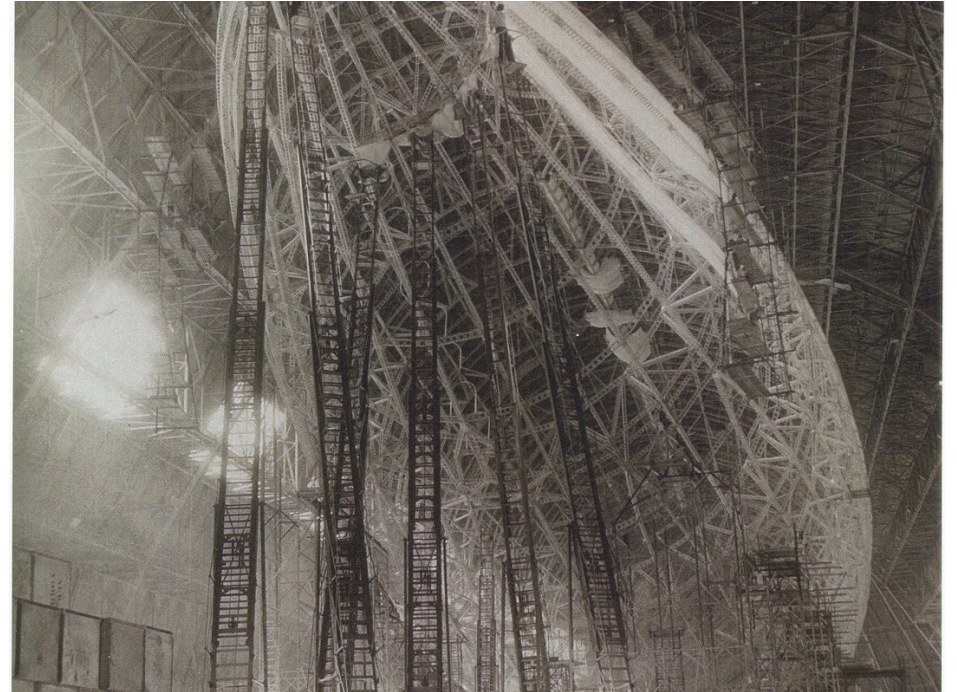

**Development**

# Development | Structure Iterations

Version One

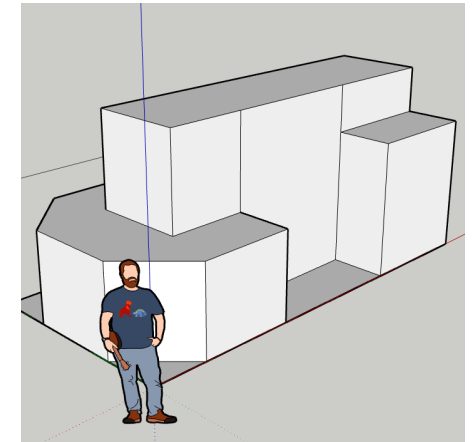
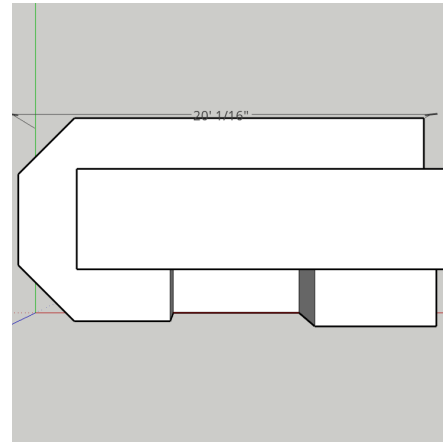

Version Two

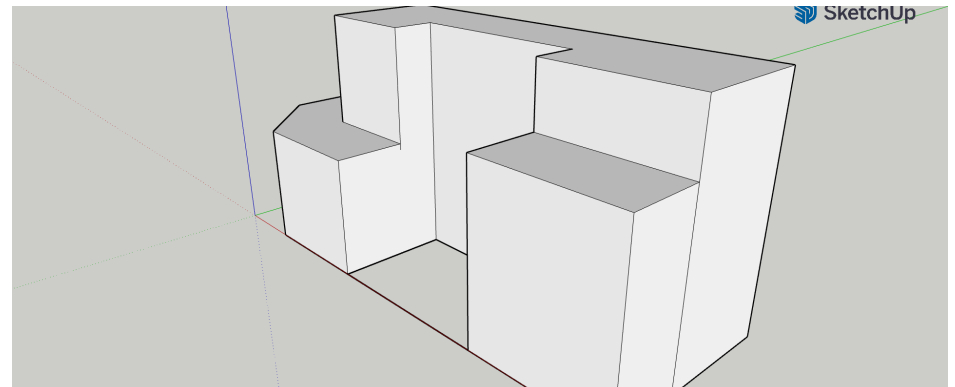
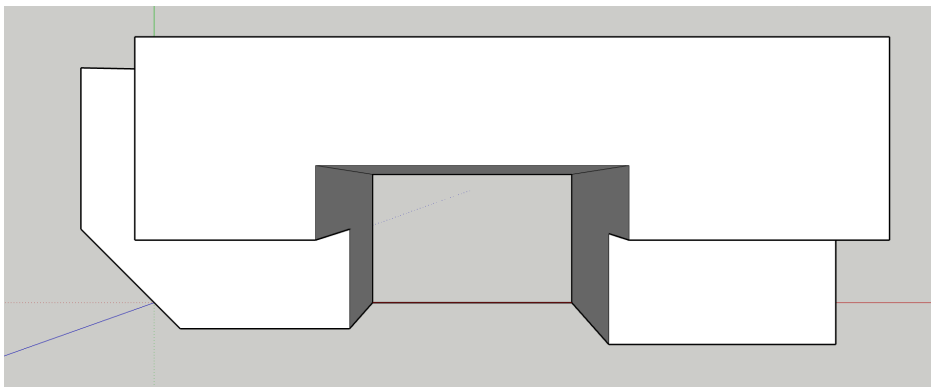
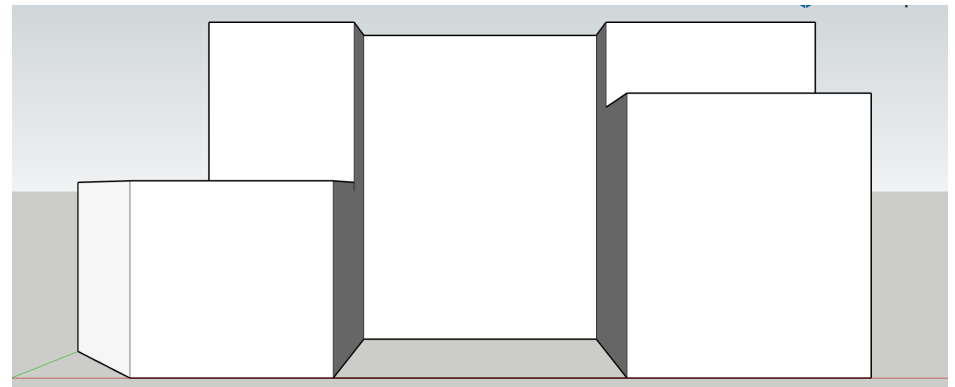
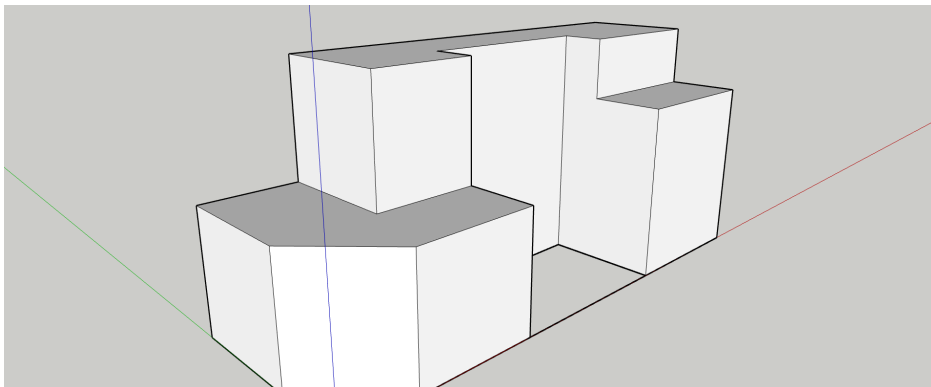

# Development | Structure Iterations

Version Three

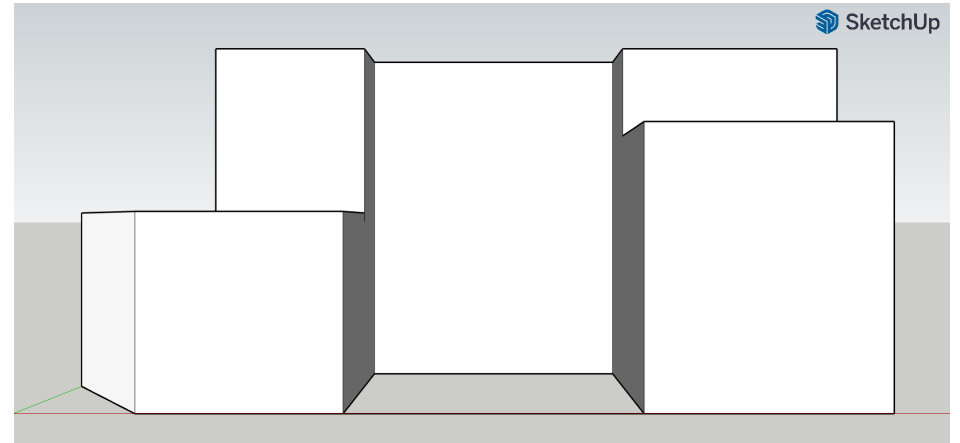

Version Four

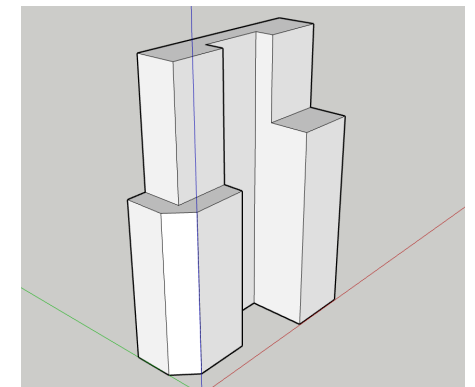
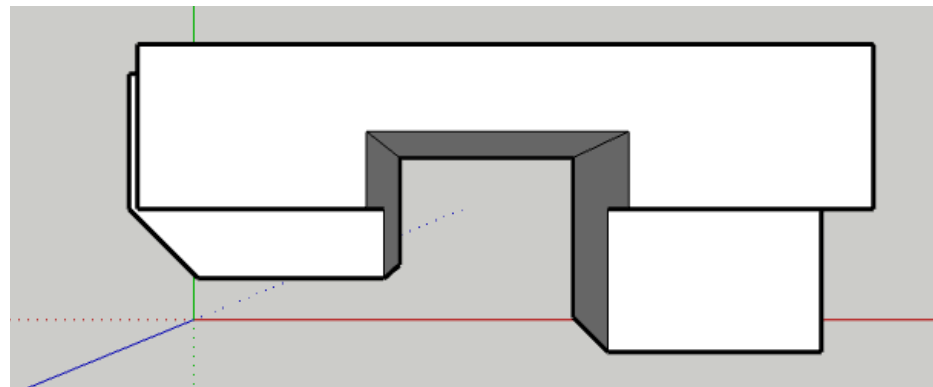
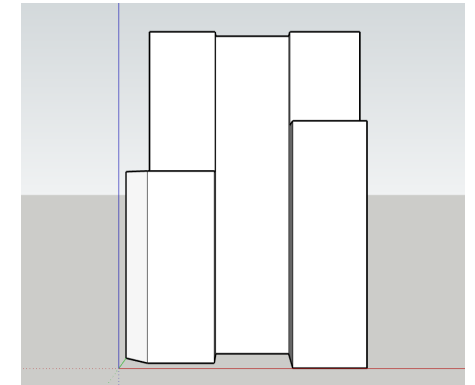
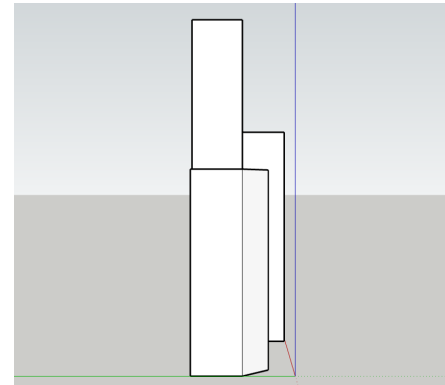



## Development | Structure Iterations

### Version Five

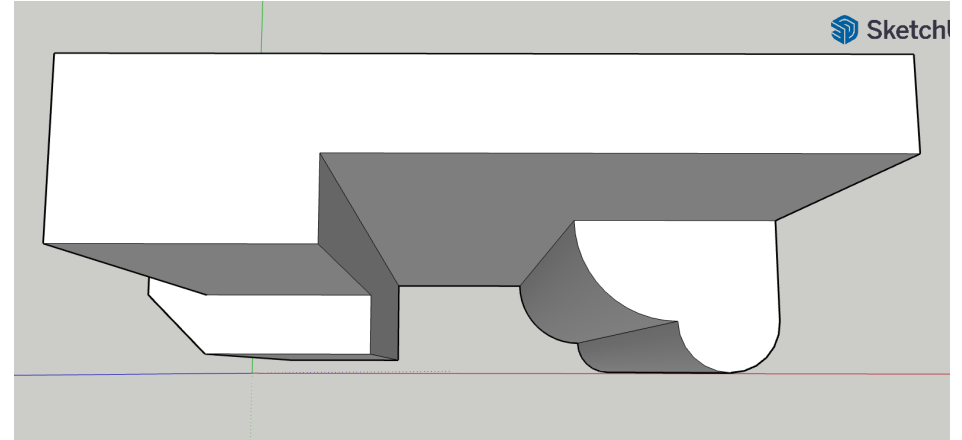
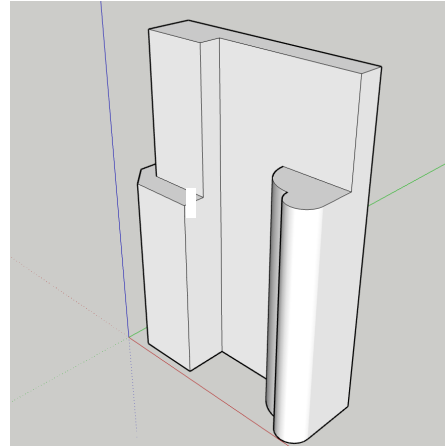
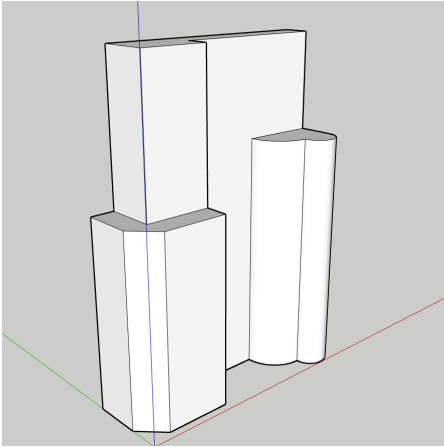

### Version Six

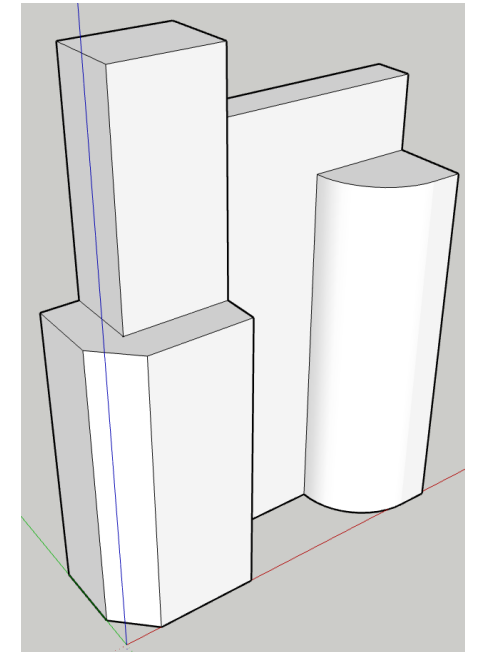
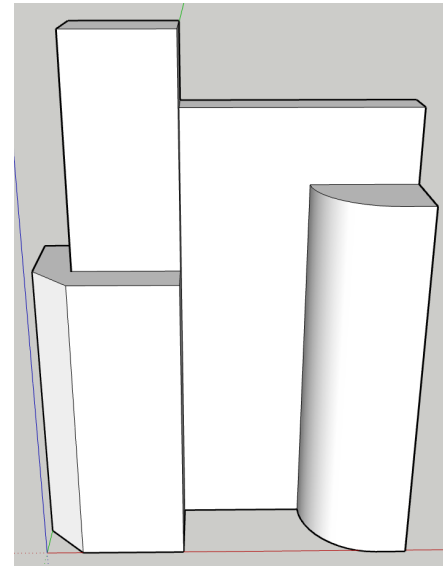
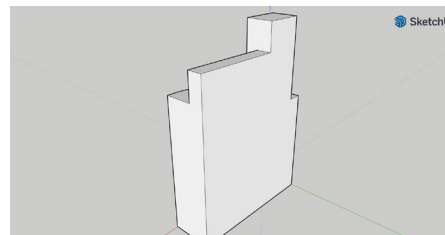
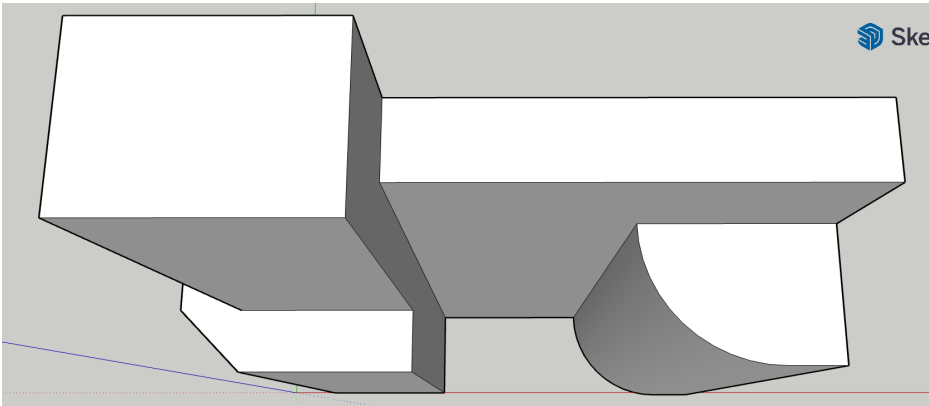

Development | 3D Model

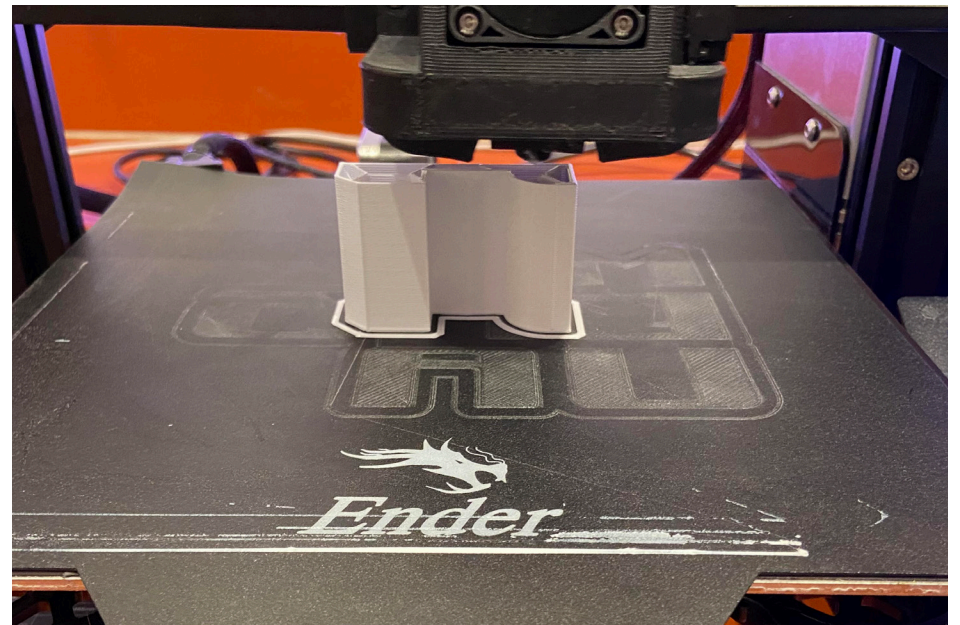
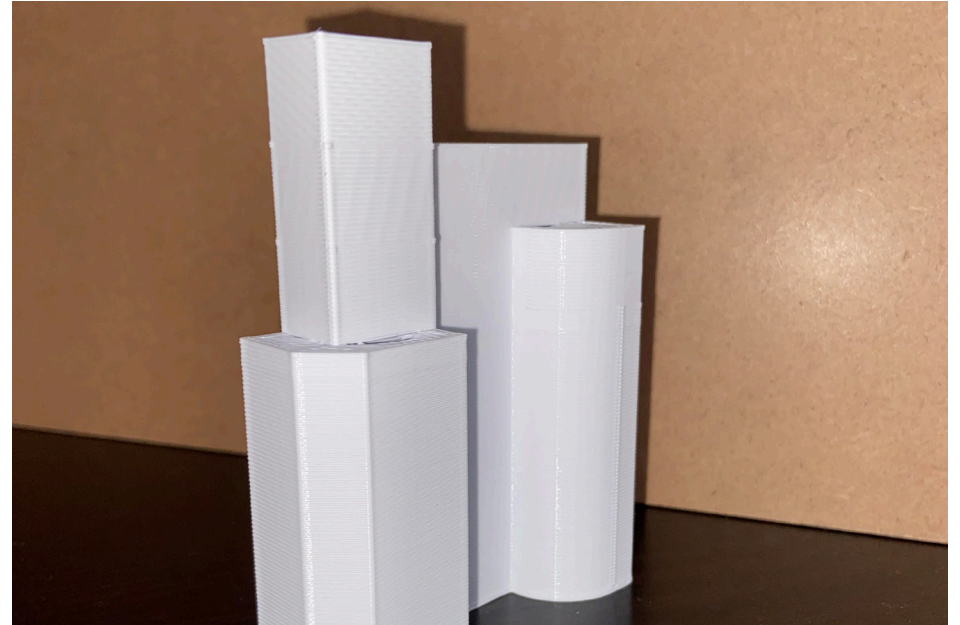
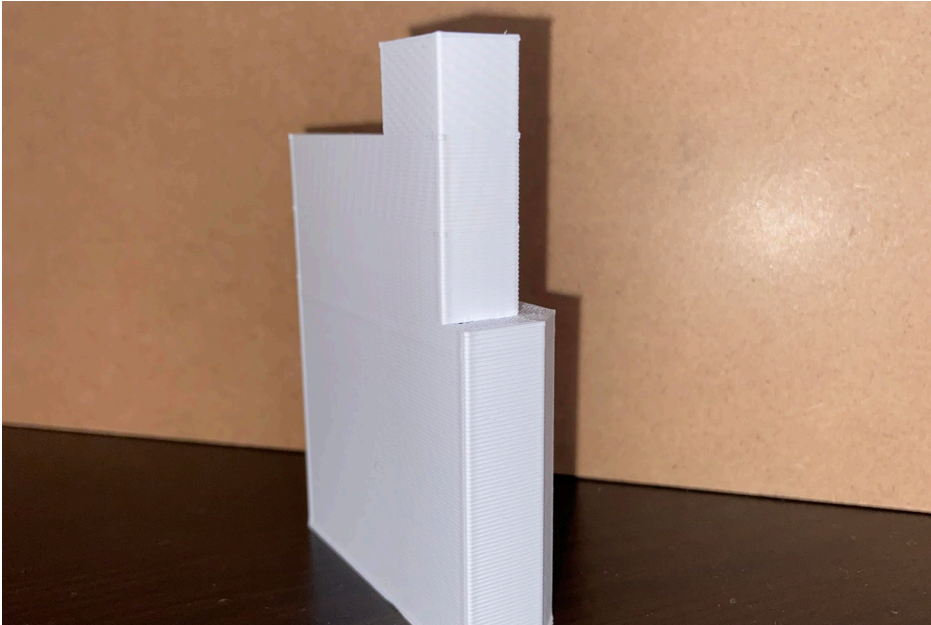

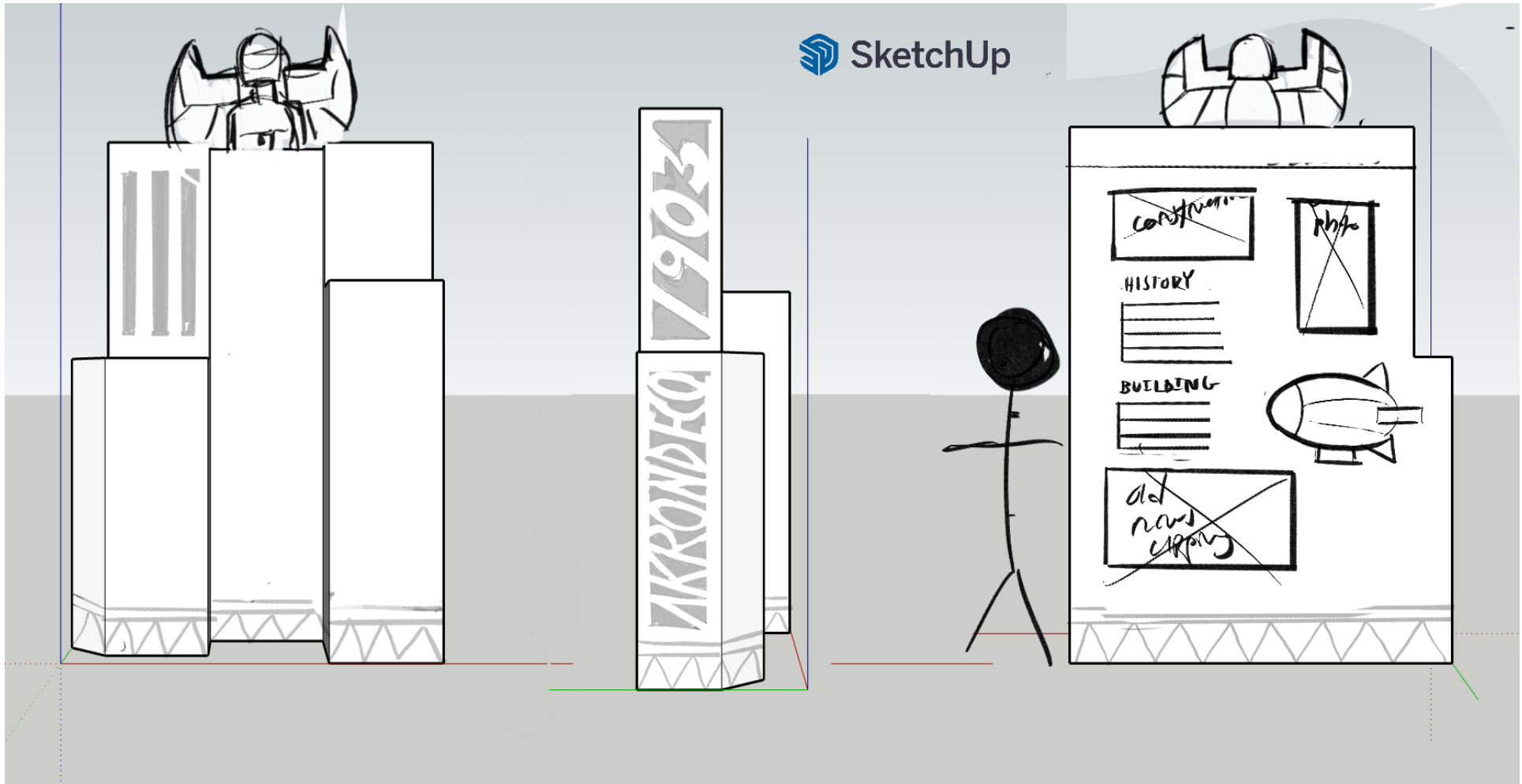

# Development | Type Pairings

## ANISETTE STD

### Serenity

**AA BB CC DD EE FF GG HH II JJ KK LL MM NN OO**

**PP QQ RR SS TT UU VV WW XX YY ZZ ?!\$%**

Aa Bb Cc Dd Ee Ff Gg Hh Ii Jj Kk Ll Mm Nn Oo Pp

Qq Rr Ss Tt Uu Vv Ww Xx Yy Zz ?!\$%

## ANISETTE STD

### Mendl Sans

**AA BB CC DD EE FF GG HH II JJ KK LL MM NN OO**

**PP QQ RR SS TT UU VV WW XX YY ZZ ?!\$%**

Aa Bb Cc Dd Ee Ff Gg Hh Ii Jj Kk Ll Mm Nn Oo Pp

Qq Rr Ss Tt Uu Vv Ww Xx Yy Zz ?!\$%

## ANISETTE STD

### News Gothic Std

**AA BB CC DD EE FF GG HH II JJ KK LL MM NN OO**

**PP QQ RR SS TT UU VV WW XX YY ZZ ?!\$%**

Aa Bb Cc Dd Ee Ff Gg Hh Ii Jj Kk Ll Mm Nn Oo

Pp Qq Rr Ss Tt Uu Vv Ww Xx Yy Zz ?!\$%

## CAPITOL

### News Gothic Std

**AA BB CC DD EE FF GG HH II JJ KK LL MM NN OO PP QQ RR SS TT**

**UU VV WW XX YY ZZ ?!\$%**

Aa Bb Cc Dd Ee Ff Gg Hh Ii Jj Kk Ll Mm Nn Oo

Pp Qq Rr Ss Tt Uu Vv Ww Xx Yy Zz ?!\$%

## CAPITOL

### Serenity

**AA BB CC DD EE FF GG HH II JJ KK LL MM NN OO PP QQ RR SS TT**

**UU VV WW XX YY ZZ ?!\$%**

Aa Bb Cc Dd Ee Ff Gg Hh Ii Jj Kk Ll Mm Nn Oo Pp

Qq Rr Ss Tt Uu Vv Ww Xx Yy Zz ?!\$%

## CAPITOL

### Mendl Sans

**AA BB CC DD EE FF GG HH II JJ KK LL MM NN OO PP QQ RR SS TT**

**UU VV WW XX YY ZZ ?!\$%**

Aa Bb Cc Dd Ee Ff Gg Hh Ii Jj Kk Ll Mm Nn Oo Pp

Qq Rr Ss Tt Uu Vv Ww Xx Yy Zz ?!\$%

# Development | Type Pairings

## ANISETTE STD

### Serenity

**AA BB CC DD EE FF GG HH II JJ KK LL MM NN OO**

**PP QQ RR SS TT UU VV WW XX YY ZZ ?!\$%**

Aa Bb Cc Dd Ee Ff Gg Hh Ii Jj Kk Ll Mm Nn Oo Pp

Qq Rr Ss Tt Uu Vv Ww Xx Yy Zz ?!\$%

## ANISETTE STD

### Mendl Sans

**AA BB CC DD EE FF GG HH II JJ KK LL MM NN OO**

**PP QQ RR SS TT UU VV WW XX YY ZZ ?!\$%**

Aa Bb Cc Dd Ee Ff Gg Hh Ii Jj Kk Ll Mm Nn Oo Pp

Qq Rr Ss Tt Uu Vv Ww Xx Yy Zz ?!\$%

## ANISETTE STD

### News Gothic Std

**AA BB CC DD EE FF GG HH II JJ KK LL MM NN OO**

**PP QQ RR SS TT UU VV WW XX YY ZZ ?!\$%**

Aa Bb Cc Dd Ee Ff Gg Hh Ii Jj Kk Ll Mm Nn Oo

Pp Qq Rr Ss Tt Uu Vv Ww Xx Yy Zz ?!\$%

## CAPITOL

### News Gothic Std

**AA BB CC DD EE FF GG HH II JJ KK LL MM NN OO PP QQ RR SS TT**

**UU VV WW XX YY ZZ ?!\$%**

Aa Bb Cc Dd Ee Ff Gg Hh Ii Jj Kk Ll Mm Nn Oo

Pp Qq Rr Ss Tt Uu Vv Ww Xx Yy Zz ?!\$%

## CAPITOL

### Serenity

**AA BB CC DD EE FF GG HH II JJ KK LL MM NN OO PP QQ RR SS TT**

**UU VV WW XX YY ZZ ?!\$%**

Aa Bb Cc Dd Ee Ff Gg Hh Ii Jj Kk Ll Mm Nn Oo Pp

Qq Rr Ss Tt Uu Vv Ww Xx Yy Zz ?!\$%

## CAPITOL

### Mendl Sans

**AA BB CC DD EE FF GG HH II JJ KK LL MM NN OO PP QQ RR SS TT**

**UU VV WW XX YY ZZ ?!\$%**

Aa Bb Cc Dd Ee Ff Gg Hh Ii Jj Kk Ll Mm Nn Oo Pp

Qq Rr Ss Tt Uu Vv Ww Xx Yy Zz ?!\$%

Development | Model Sketches

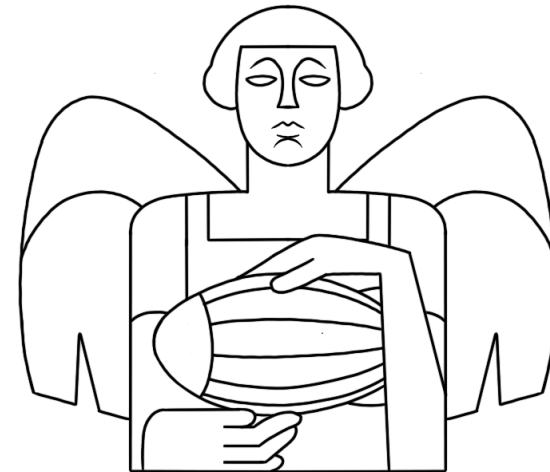
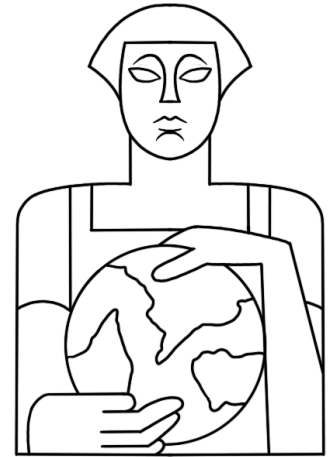
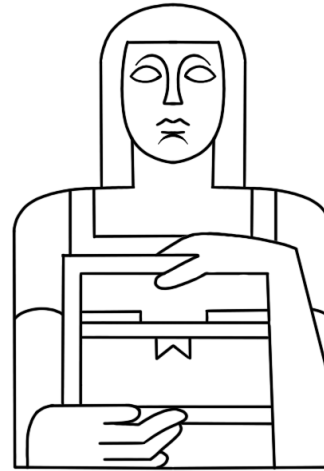
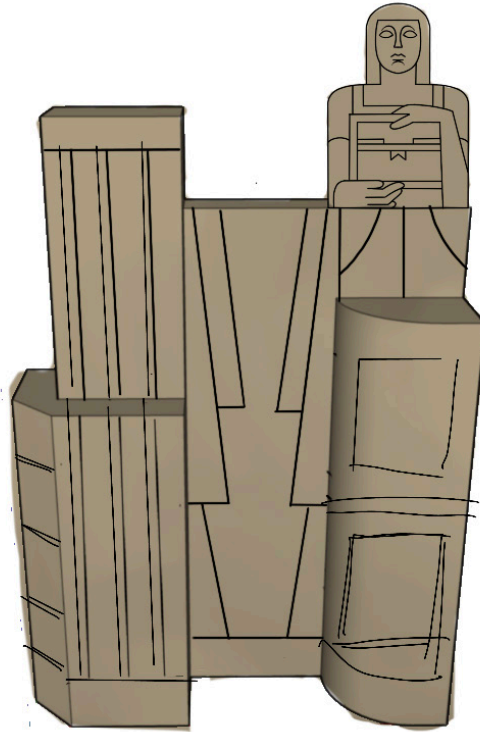

1931

## HUNTINGTON TOWER

### HISTORY

In this 1920s photo on the right, the neo-gothic Hamilton Building is shown at the site at Main and Mill streets that is now occupied by the Huntington Bank Tower.

As the brightest jewel of the Akron skyline, the Huntington Tower, once known as the FirstMerit Tower, is easily identifiable from any downtown vantage point.

Standing tall at a coincidental 330 feet, the Art-Deco style building was completed in 1931 by the architectural firm Walker & Weeks as headquarters for the Central Depositors Bank and Trust, and remains Akron's tallest skyscraper to-date.



## AKRON DECO

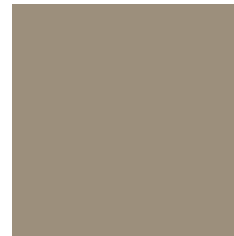
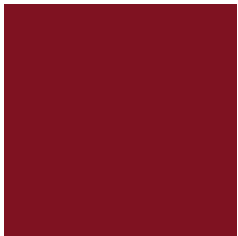
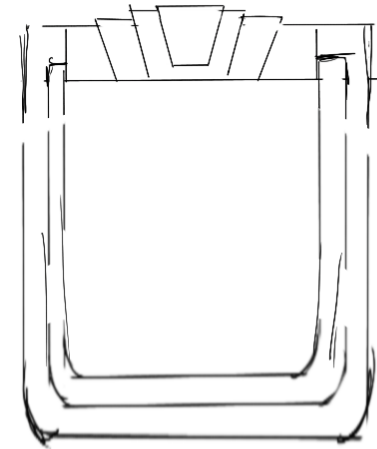
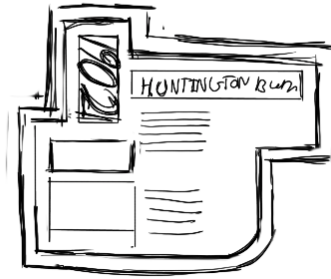

Development | Materials Proposal

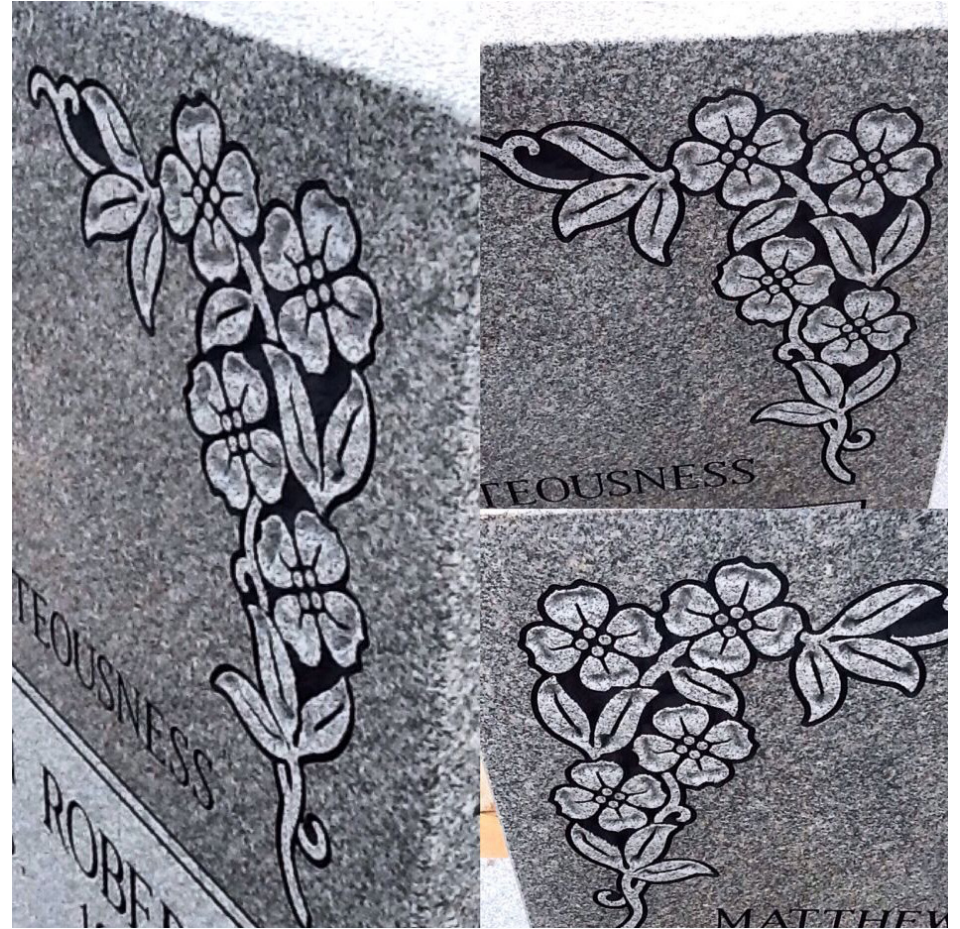



**Finals**

Finals | Huntington Tower | South and West View





Finals | Akron YMCA Building | South and West View





## AKRON YMCA BUILDING

### HISTORY

Constructed in 1928, the Akron YMCA Building was designed by architect Philip Johnson in the modernist style of the Art Deco movement. It was one of the first skyscrapers in the world to be constructed with a steel frame. The building was the first to use a steel frame structure, which was revolutionary at the time.

In the early 20th century, the YMCA was a leading organization in providing social and recreational activities for young men. The Akron YMCA Building was a landmark in the city, providing a place for young men to gather and socialize.

The Akron YMCA Building was a landmark in the city, providing a place for young men to gather and socialize. It was a place where young men could find a sense of community and belonging.

### BUILDING

The Akron YMCA Building is a prime example of the Art Deco style. It features a steel frame structure, which was revolutionary at the time. The building is a landmark in the city, providing a place for young men to gather and socialize.

The building is a landmark in the city, providing a place for young men to gather and socialize. It was a place where young men could find a sense of community and belonging.



Finals | Akron-Fulton Intl Airport | South and West View

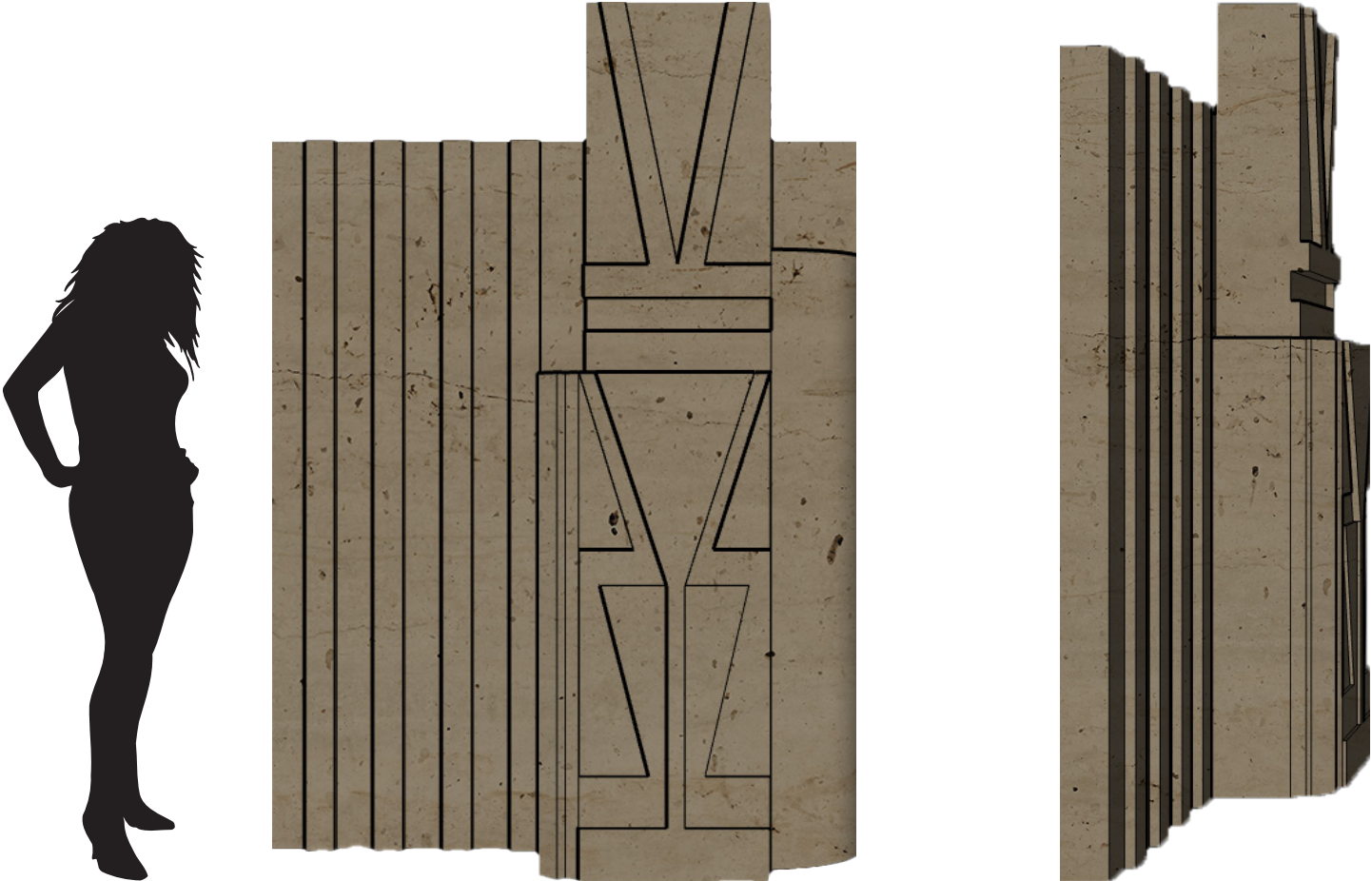



## AKRON FULTON INTL AIRPORT

### HISTORY

The Akron Fulton Airport was dedicated in 1932 and has long served as a major aviation hub for the region. It was the first airport in the world to have a terminal building, a hangar, and a control tower. The airport was built on a site that was once a farm. The land was purchased by the city of Akron in 1918. The airport was built on a site that was once a farm. The land was purchased by the city of Akron in 1918. The airport was built on a site that was once a farm. The land was purchased by the city of Akron in 1918.

### BUILDING

The building was a significant contribution to the development of the local aviation industry. It was the first airport in the world to have a terminal building, a hangar, and a control tower. The building was built on a site that was once a farm. The land was purchased by the city of Akron in 1918. The airport was built on a site that was once a farm. The land was purchased by the city of Akron in 1918.





## HUNTINGTON TOWER



### HISTORY

In this 1920s photo on the left, the neo-gothic Hamilton Building is shown at the site of Main and Hill streets that is now occupied by the Huntington Bank Tower.



As the brightest jewel of the Akron skyline, the Huntington Tower, known once as the FirstMerit Tower, is easily identifiable from any downtown vantage point.

Standing tall at a coincidental 330 feet, the Art-Deco style building was completed in 1931 by the architectural firm Walker & Weeks as headquarters for the Central Depositors Bank and Trust, and remains Akron's tallest skyscraper to-date.

1931

AKRON DECO



## HUNTINGTON TOWER

### HISTORY

Completed in 1916, the Huntington Building in Akron, Ohio, is a defining example of the Art Deco style, reflecting the design sensibilities of the 1920s. It was designed by the architectural firm of Gordon, Brown, Puckett & White. The building stands as a testament to the building's grandeur and style.

On the occasion of its 100th anniversary, the building and its architectural significance are being celebrated through a series of events, including a special exhibition and a commemorative program.

The building's design is a blend of Art Deco and traditional architectural elements, showcasing the innovative spirit of the era. It stands as a symbol of Akron's architectural heritage and its role in the development of the city.

### BUILDING

The building of the Huntington Building is a masterpiece of Art Deco architecture, designed by the architectural firm of Gordon, Brown, Puckett & White. The building's design is a blend of Art Deco and traditional architectural elements, showcasing the innovative spirit of the era.

The building's design is a blend of Art Deco and traditional architectural elements, showcasing the innovative spirit of the era. It stands as a symbol of Akron's architectural heritage and its role in the development of the city.

The building's design is a blend of Art Deco and traditional architectural elements, showcasing the innovative spirit of the era. It stands as a symbol of Akron's architectural heritage and its role in the development of the city.



## AKRON YMCA BUILDING

### HISTORY

In 1916, the Akron YMCA Building was designed by architect Charles S. Schuchman. The building is a prime example of the Art Deco style, reflecting the design sensibilities of the 1920s. It was designed by the architectural firm of Gordon, Brown, Puckett & White.

The building's design is a blend of Art Deco and traditional architectural elements, showcasing the innovative spirit of the era. It stands as a symbol of Akron's architectural heritage and its role in the development of the city.

The building's design is a blend of Art Deco and traditional architectural elements, showcasing the innovative spirit of the era. It stands as a symbol of Akron's architectural heritage and its role in the development of the city.

### BUILDING

The Akron YMCA Building is a masterpiece of Art Deco architecture, designed by the architectural firm of Gordon, Brown, Puckett & White. The building's design is a blend of Art Deco and traditional architectural elements, showcasing the innovative spirit of the era.

The building's design is a blend of Art Deco and traditional architectural elements, showcasing the innovative spirit of the era. It stands as a symbol of Akron's architectural heritage and its role in the development of the city.

The building's design is a blend of Art Deco and traditional architectural elements, showcasing the innovative spirit of the era. It stands as a symbol of Akron's architectural heritage and its role in the development of the city.



## AKRON FULTON INTL AIRPORT

### HISTORY

The Akron Fulton International Airport was designed by architect Charles S. Schuchman. The building is a prime example of the Art Deco style, reflecting the design sensibilities of the 1920s. It was designed by the architectural firm of Gordon, Brown, Puckett & White.

The building's design is a blend of Art Deco and traditional architectural elements, showcasing the innovative spirit of the era. It stands as a symbol of Akron's architectural heritage and its role in the development of the city.

The building's design is a blend of Art Deco and traditional architectural elements, showcasing the innovative spirit of the era. It stands as a symbol of Akron's architectural heritage and its role in the development of the city.

### BUILDING

The Akron Fulton International Airport is a masterpiece of Art Deco architecture, designed by the architectural firm of Gordon, Brown, Puckett & White. The building's design is a blend of Art Deco and traditional architectural elements, showcasing the innovative spirit of the era.

The building's design is a blend of Art Deco and traditional architectural elements, showcasing the innovative spirit of the era. It stands as a symbol of Akron's architectural heritage and its role in the development of the city.

The building's design is a blend of Art Deco and traditional architectural elements, showcasing the innovative spirit of the era. It stands as a symbol of Akron's architectural heritage and its role in the development of the city.

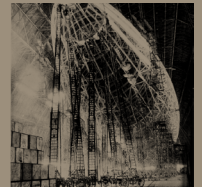

## AKRON-FULTON INTL AIRPORT

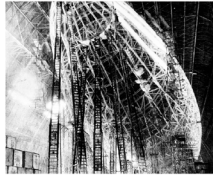

### HISTORY

The Akron-Fulton Administration building sits just north of the Goodyear Airdock, where the first lighter-than-air ships were produced. It also stands as one of the few Goodyear Blimp hangars to exist.

The building serves a significant contribution to the development of early commercial aviation in Akron. Both its Art Deco architecture and interior are representations of the development of airports during the first major expansion of air travel in the 1920s and 1930s.



In 1985, the Akron Fulton International Airport was recognized as the 3rd National Landmark of Soaring by the National Soaring Museum.

1929

AKRON DECO

## AKRON YMCA BUILDING



### HISTORY

The Akron YMCA building was envisioned as more than just a recreational facility; it was a space where individuals could engage in fitness activities, educational programs, and social gatherings.

In the mid-20th century, the space underwent renovations to modernize its facilities. New amenities were added and these improvements allowed the YMCA to better meet the changing needs of the community and adapt to shifting social dynamics.



The YMCA is still in the building for which it is named, but they no longer own the building, and now lease their space from the owner.

1930

AKRON DECO

## HUNTINGTON TOWER



### HISTORY

In this 1920s photo on the left, the neo-gothic Hamilton Building is shown at the site at Main and Mill streets that is now occupied by the Huntington Bank Tower.



As the brightest jewel of the Akron skyline, the Huntington Tower, known once as the FirstMerit Tower, is easily identifiable from any downtown vantage point.

Standing tall at a coincidental 330 feet, the Art-Deco style building was completed in 1931 by the architectural firm Walker & Weeks as headquarters for the Central Depositors Bank and Trust, and remains Akron's tallest skyscraper to-date.

1931

AKRON DECO

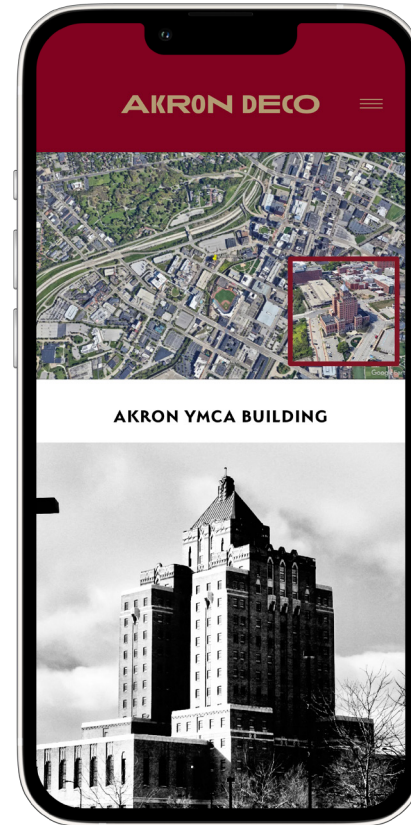
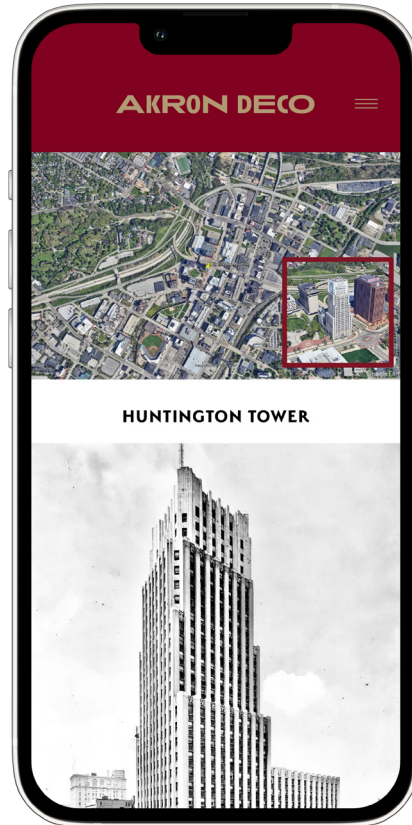
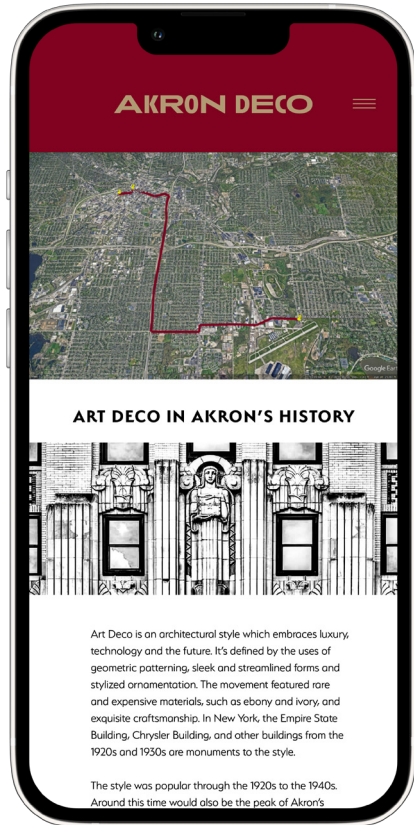

Finals | Actual Space



**Elevations + Dimensions**

Elevations + Dimensions | Huntington Tower | South and West View

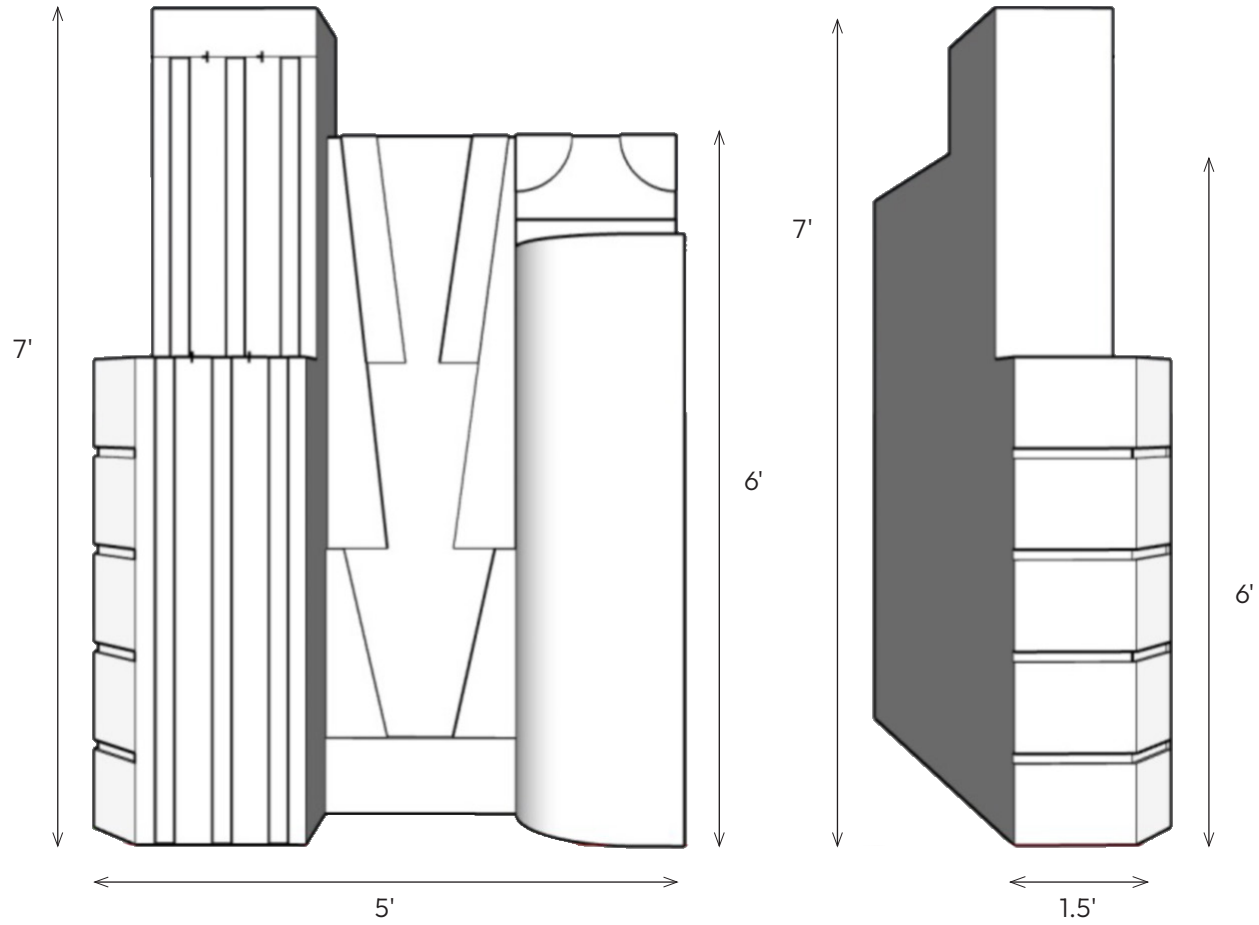

# Elevations + Dimensions | Huntington Tower | East and North View

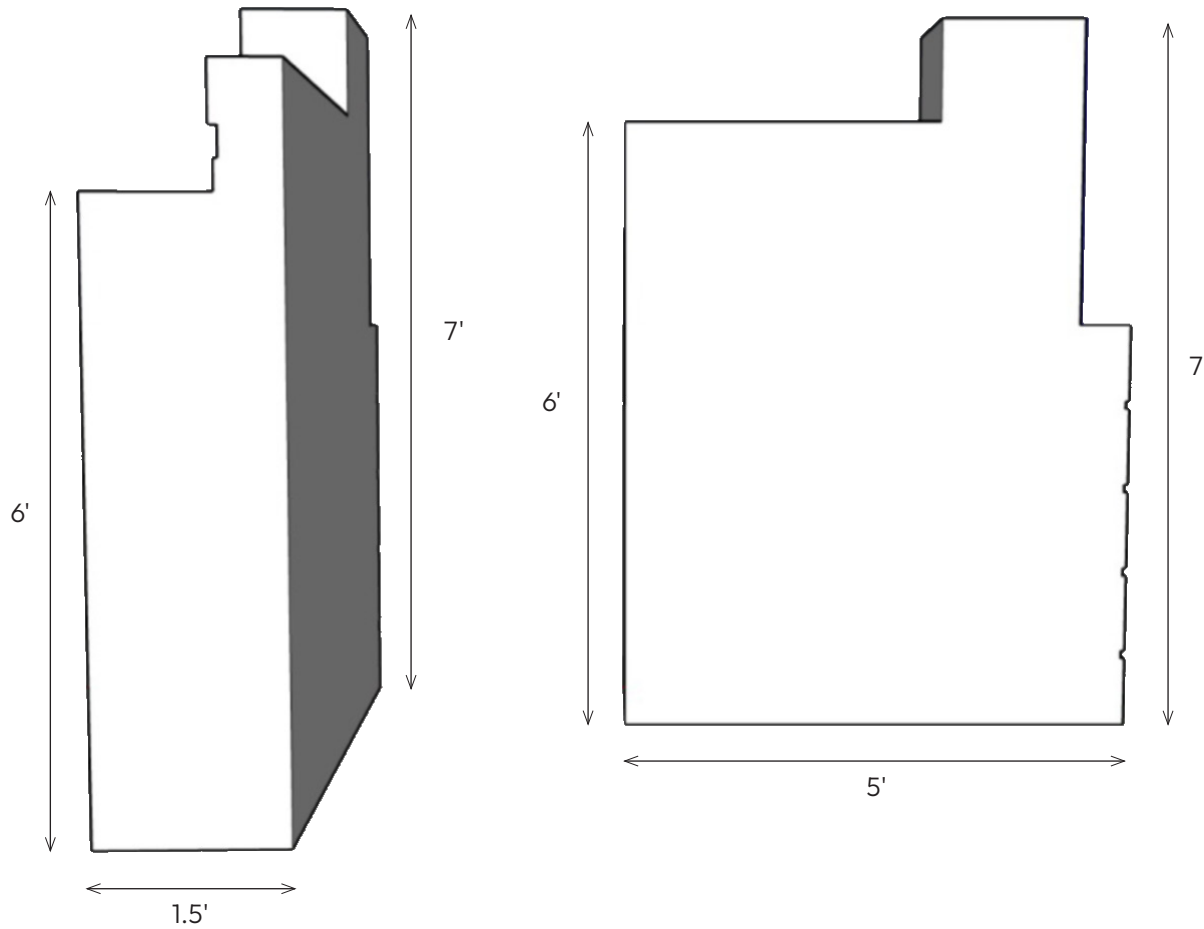

Elevations + Dimensions | Huntington Tower | Plan View

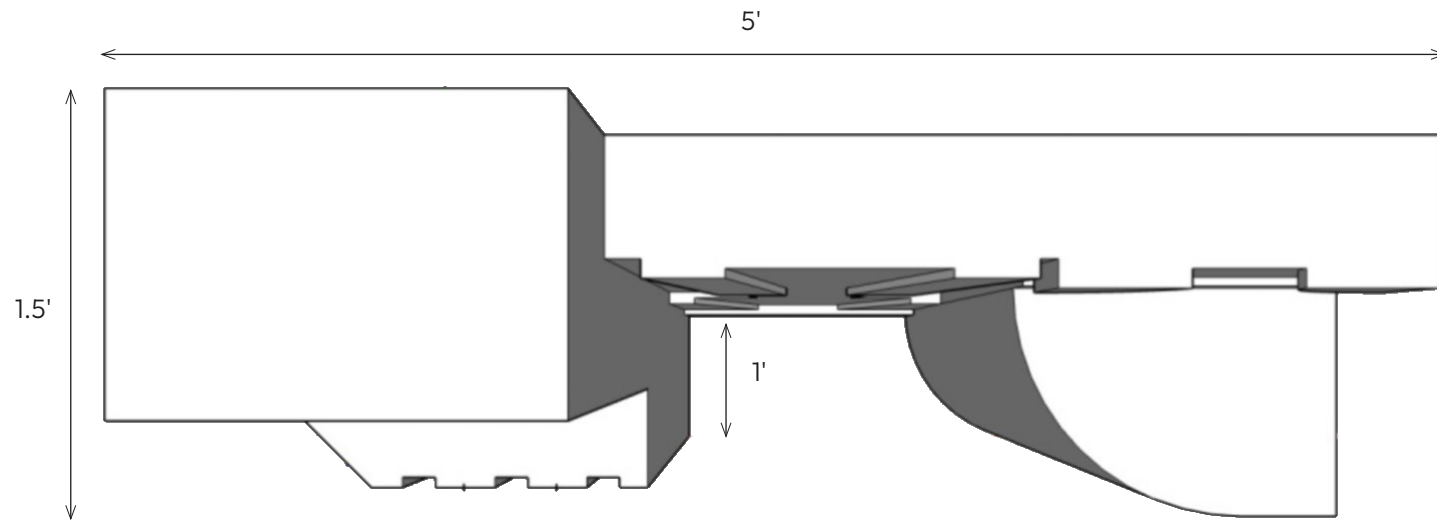



Elevations + Dimensions | Akron YMCA Building | West and South View

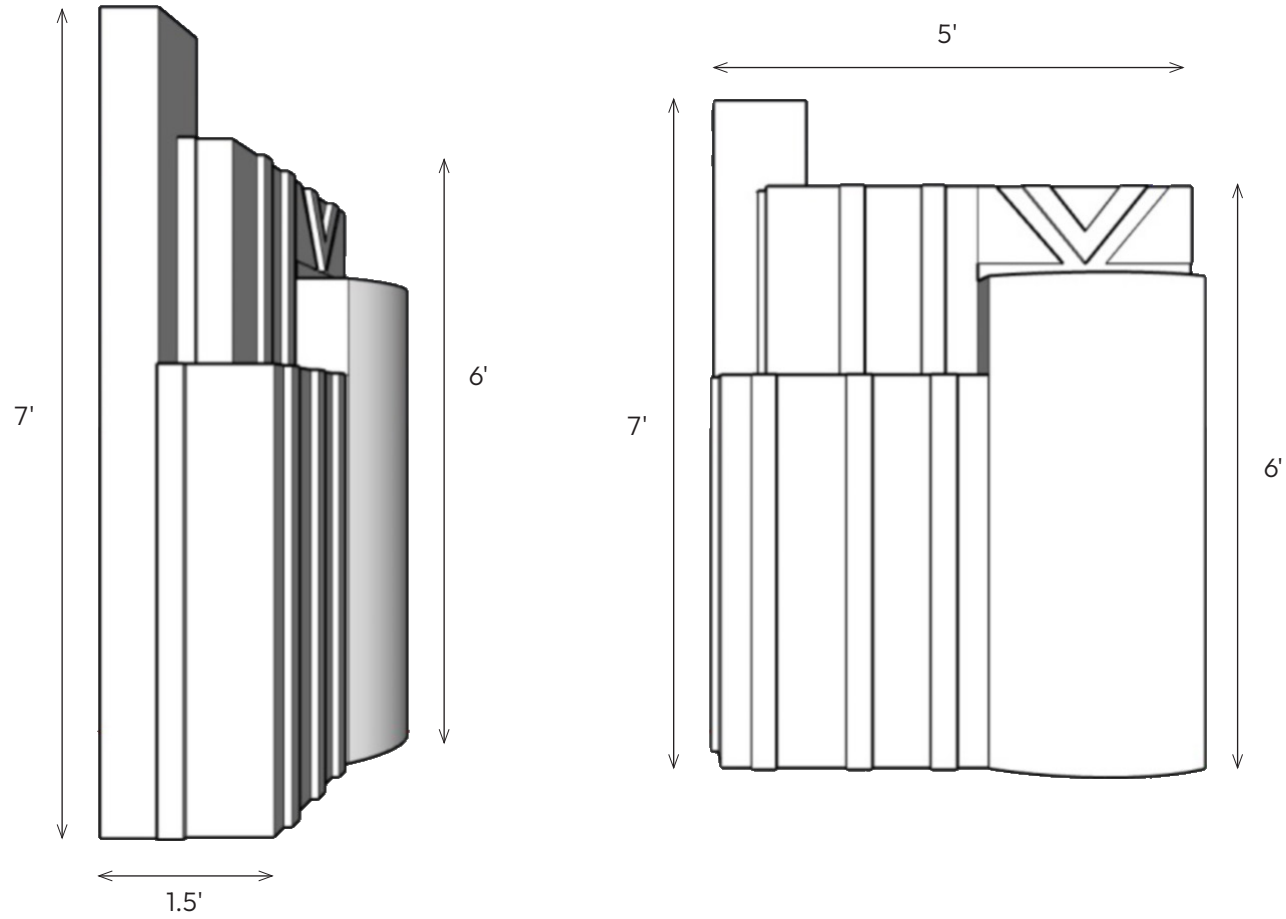

Elevations + Dimensions | Akron YMCA Building | North and East View

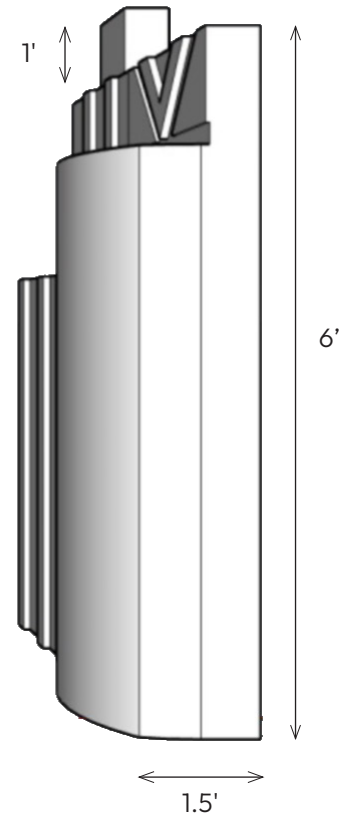
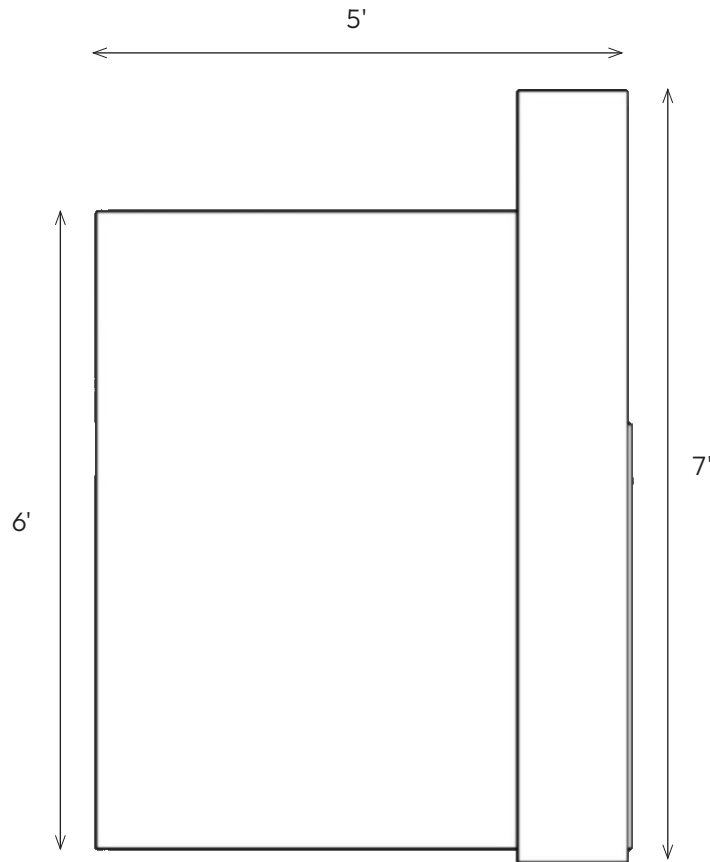

Elevations + Dimensions | Akron YMCA Building | Plan View

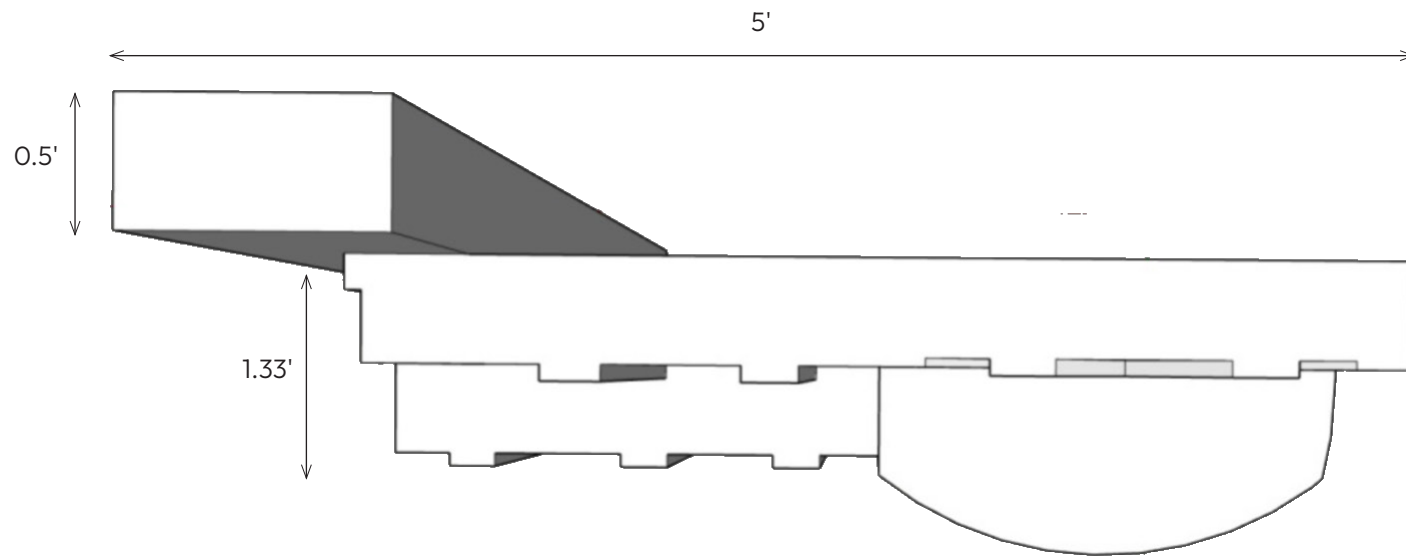

Elevations + Dimensions | Akron-Fulton Intl Airport | South and East View

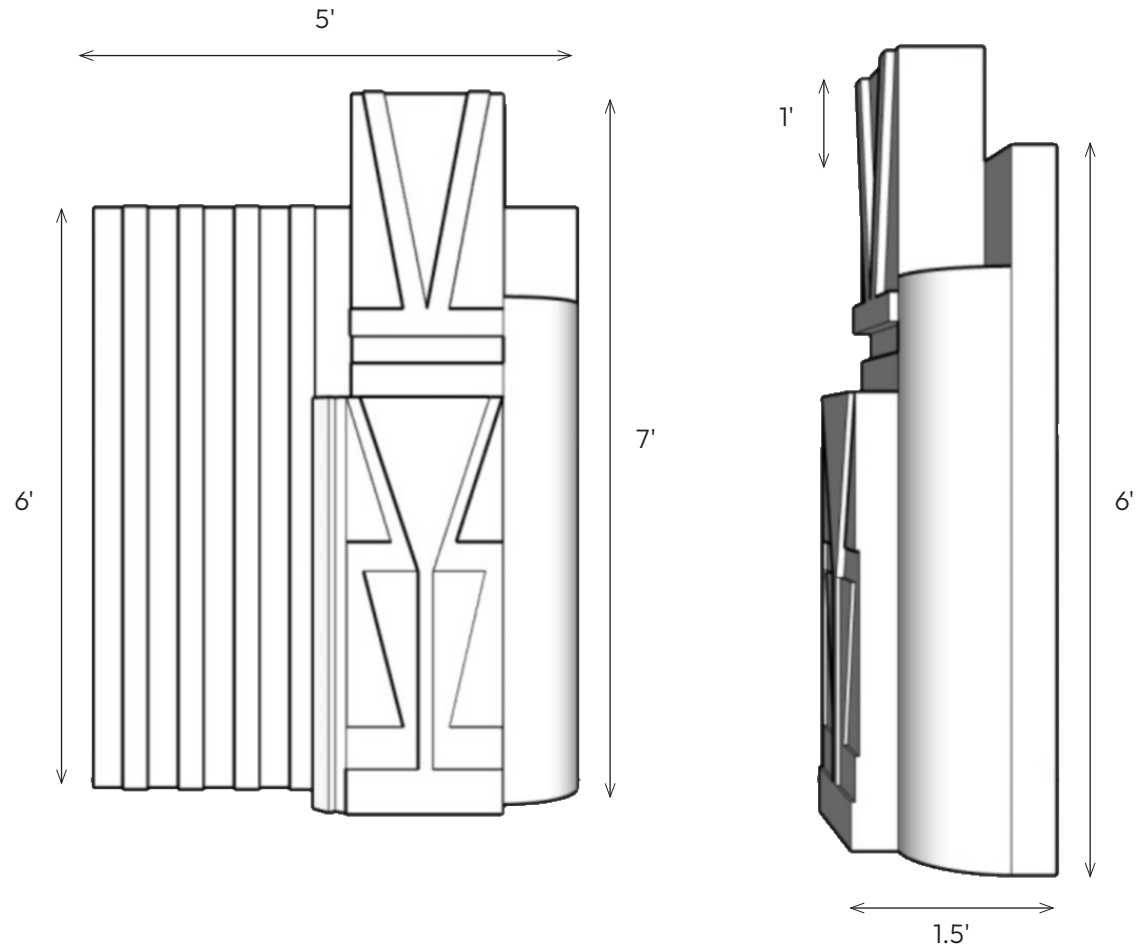

Elevations + Dimensions | Akron-Fulton Intl Airport | West and North View

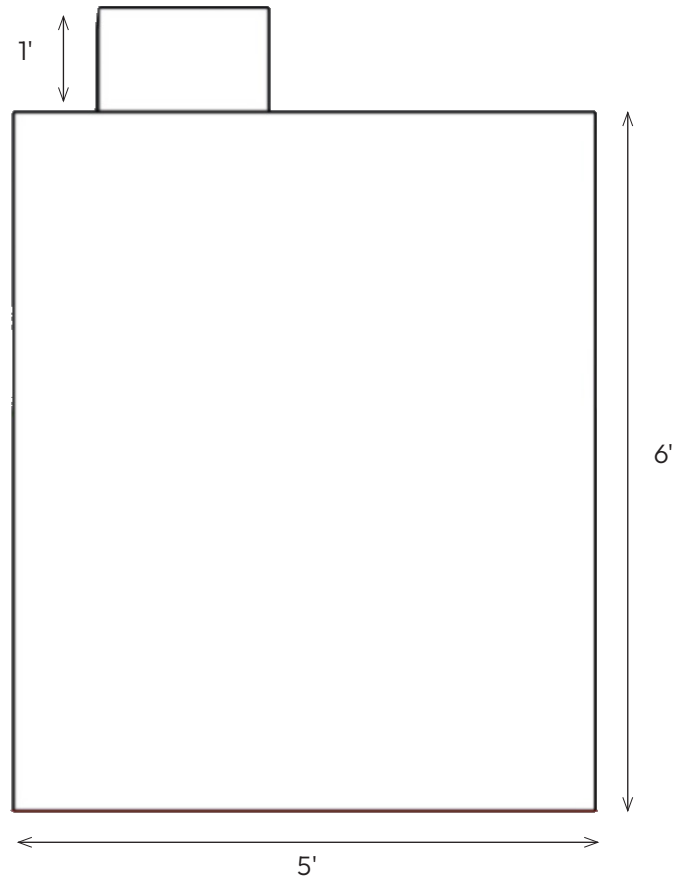
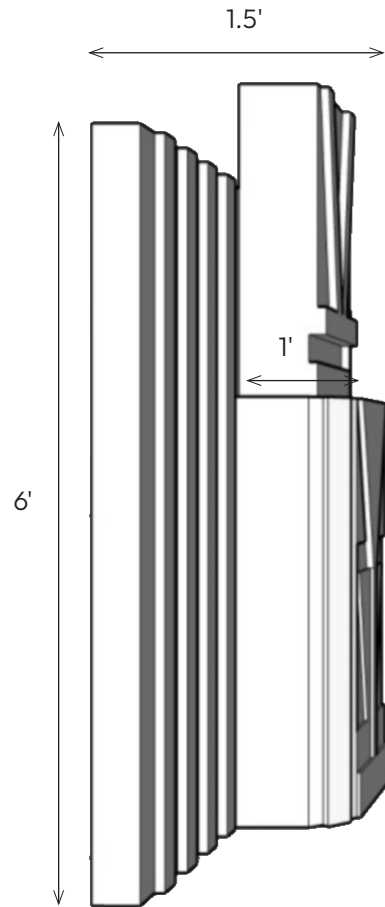

Elevations + Dimensions | Akron-Fulton Intl Airport | Plan View

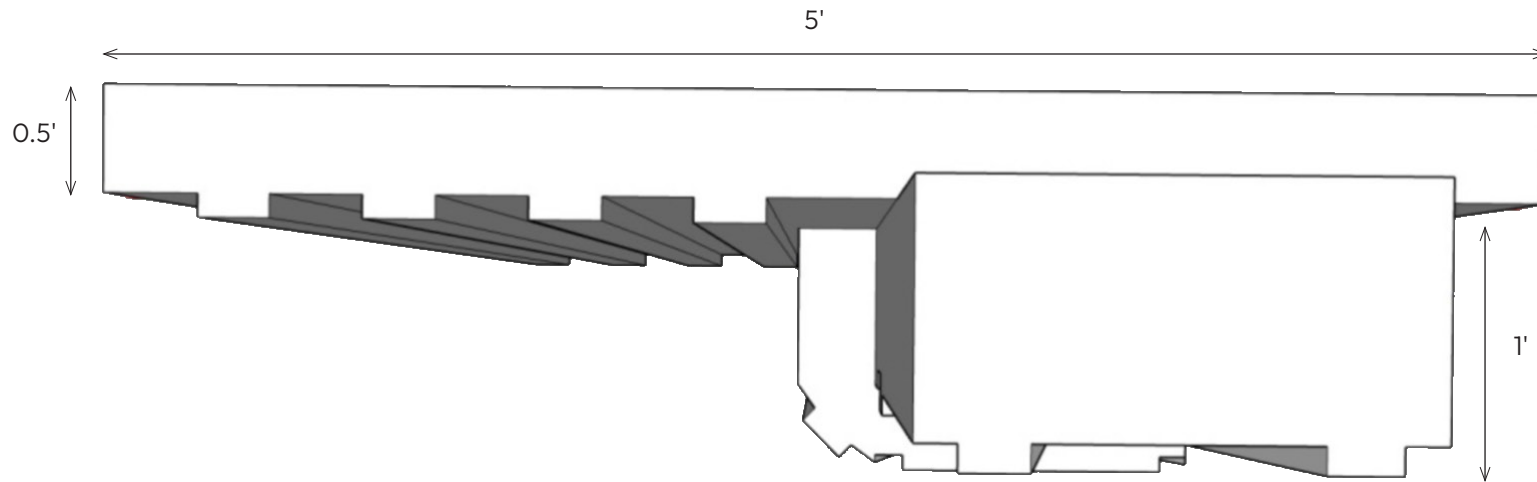

Elevations + Dimensions | Signage North View

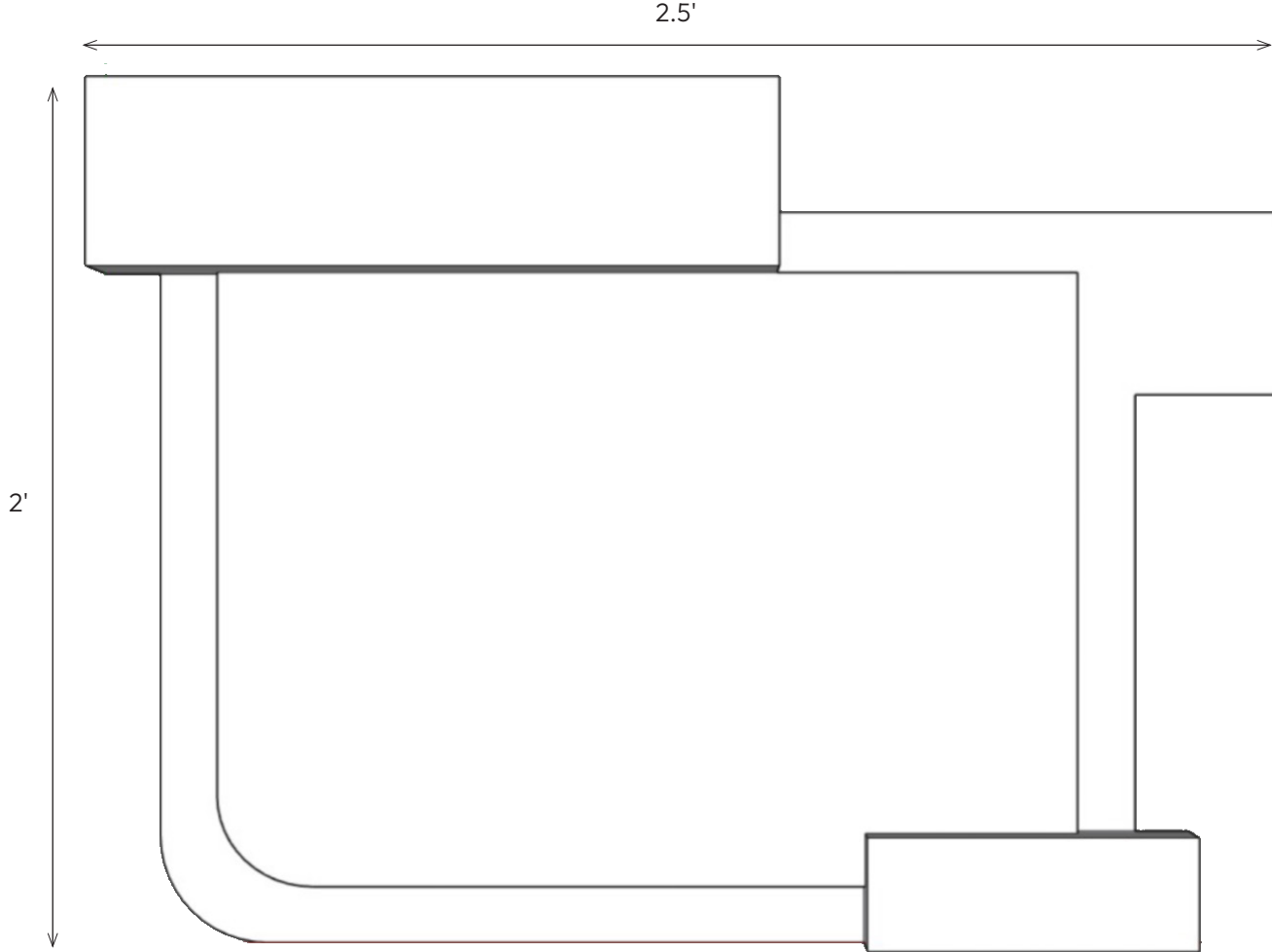

Elevations + Dimensions | Signage Plan View

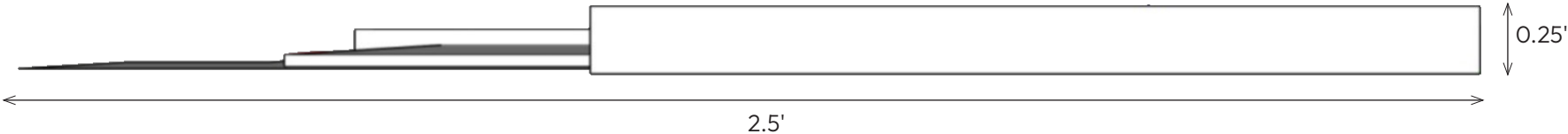



Elevations + Dimensions | Signage East View

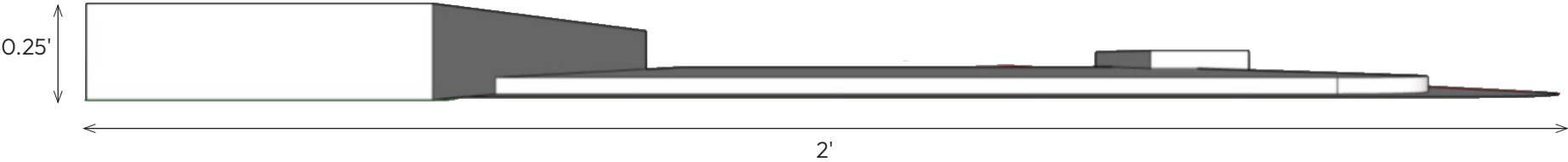

Elevations + Dimensions | Signage West View

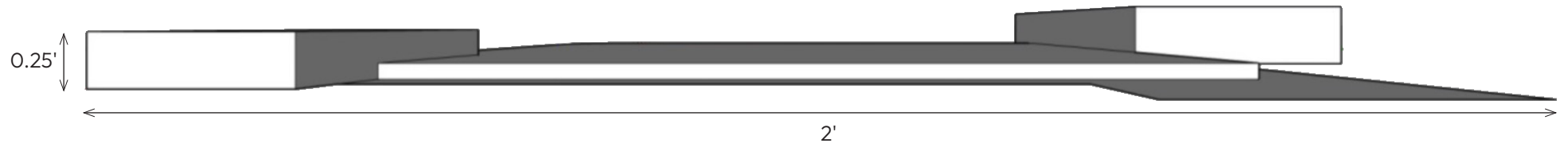

## Team Credits

**Tyler Henretty:** Research, Modeling, Editing, Process Book

**Kim Finch:** Research, Editing, Process Book, Interior Signage, App

**Justin Morris:** Photography, Type, Editing, Exterior Signage